

Establishing More Truth in True Winds

SHAWN R. SMITH, MARK A. BOURASSA, AND RYAN J. SHARP

Center for Ocean–Atmospheric Prediction Studies, The Florida State University, Tallahassee, Florida

27 October 1997 and 29 October 1998

ABSTRACT

Techniques are presented for the computation and quality control of true winds from vessels at sea. Correct computation of true winds and quality-control methods are demonstrated for complete data. Additional methods are presented for estimating true winds from incomplete data. Recommendations are made for both existing data and future applications.

Quality control of automated weather station (AWS) data at the World Ocean Circulation Experiment Surface Meteorological Data Center reveals that only 20% of studied vessels report all parameters necessary to compute a true wind. Required parameters include the ship's heading, course over the ground (COG), speed over the ground, wind vane zero reference, and wind speed and direction relative to the vessel. If any parameter is omitted or incorrect averaging is applied, AWS true wind data display systematic errors. Quantitative examples of several problems are shown in comparisons between collocated winds from research vessels and the NASA scatterometer (NSCAT). Procedures are developed to identify observational shortcomings and to quantify the impact of these shortcomings in the determination of true wind observations.

Methods for estimating true winds are presented for situations where heading or COG is missing. Empirical analysis of two vessels with high-quality AWS data showed these estimates to be more accurate when the vessel heading is available. Large differences between the heading and COG angles at low ship speeds make winds estimated using the course unreliable (direction errors exceeding 60°) for ship speeds less than 2.0 m s^{-1} . The threshold where the direction difference between a course estimated and true wind reaches an acceptable level ($\pm 10^\circ$) depends upon the ship, winds, and currents in the vessel's region of operation.

1. Introduction

Techniques are presented to calculate and quality control true winds from automated observations collected on sea-going vessels. The true wind is defined herein as a vector wind with a speed referenced to the fixed earth and a direction referenced to true north. These techniques are developed to improve the accuracy of true winds calculated by maritime automated weather systems (AWS). The need for accurate true winds from ships arises from a desire to improve the quality of flux fields over the ocean, coupled ocean–atmospheric modeling, operational forecasting, and over-water climatologies. Correct true wind calculations are provided as a tutorial and quality-control procedures are developed to identify shortcomings in existing data reporting and recording practices. Methods for estimating true winds from incomplete data are shown and evaluated. Recommendations are made for both existing data and future applications.

Numerous problems relevant to true winds are identified by the quality-control team at the World Ocean Circulation Experiment Surface Meteorological Data Center (WOCE-MET) using data from 20 AWS equipped vessels. One serious problem is incomplete or inaccurate reporting of both navigation and measured wind parameters. The parameters necessary to compute true winds include the ship's heading, the course and speed over the ground, the wind vane zero reference, and the wind direction and speed relative to the vessel. Only 20% of the studied vessels report all six parameters. Further investigation reveals an underlying confusion concerning the definition of true winds. Meteorologists, oceanographers, and members of the U.S. Merchant Marine typically define true wind differently and, as a further complication, the convention is rarely reported with the wind data. Of the 20 vessels studied, 9 report their winds using a meteorological definition, 1 uses an oceanographic definition, and the remaining 10 (50%) report no definition. Additional problems include the placement and orientation of wind instrumentation, flow distortion (Yelland et al. 1998), averaging methodology, and confusion over how to correctly compute true winds. As a result of the above problems, we can confirm the accuracy of reported true winds on only 4 of 20 studied vessels.

Corresponding author address: Mr. Shawn R. Smith, COAPS/The Florida State University, RM Johnson Bldg., Suite 200, 2035 E. Paul Dirac Drive, Tallahassee, FL 32306-2840.
E-mail: Smith@coaps.fsu.edu

TABLE 1. Definitions of wind and navigation parameters for the three most common sources of observations. Differences from the meteorological conventions are emphasized with italics. The merchant marine has two definitions of apparent wind: 1) the wind experienced on the deck of the ship with a direction referenced to true north (consistent with the meteorological definition), and 2) the wind measured by the anemometer (similar to the meteorological platform-relative wind). The merchant marine also has two definitions for true wind: 1) relative to true north, and 2) relative to the bow of the ship. The use of a zero reference angle (zero ref. ang.) measured with respect to the bow is common to all three groups.

	Velocity frame of reference	Directional frame of reference	Direction convention
Meteorological Definitions			
Ship COG and SOG	fixed earth	true north	moving to
Ship heading	fixed earth	true north	moving to
Platform-relative winds	ship	zero ref. ang.	moving from
Apparent winds	ship	true north	moving from
True winds	fixed earth	true north	moving from
Oceanographic Definitions			
Ship COG and SOG	fixed earth	true north	moving to
Ship heading	fixed earth	true north	moving to
Platform-relative winds	ship	zero ref. ang.	<i>moving to</i>
Apparent winds	ship	true north	<i>moving to</i>
True winds	fixed earth	true north	<i>moving to</i>
Merchant Marine Definitions			
Ship COG and SOG	fixed earth	true north	moving to
Ship heading	fixed earth	true north	moving to
Platform-relative winds	ship	zero ref. ang.	moving from
Apparent winds (1)	ship	true north	moving from
Apparent winds (2)	ship	<i>bow of ship</i>	moving from
True winds (1)	fixed earth	true north	moving from
True winds (2)	fixed earth	<i>bow of ship</i>	moving from

Solutions to problems with wind observations are presented for both future applications and existing (often incomplete) datasets. The presented techniques are a direct result of WOCE-MET personnel identifying, collecting, and quality controlling 181 ship months of AWS data from international research vessels. Our focus is on high-temporal resolution automated data, although most techniques can be applied to manual observations collected at standard synoptic times. Shortcomings in the observations archived by WOCE-MET lead to the obvious conclusion that future data collection and reporting must include all parameters necessary to compute a true wind. Furthermore, quality control must be applied to navigation data, measured winds, and calculated true winds to identify problems. When all necessary parameters are reported, and the methodology and quality-control procedures outlined herein are applied, an accurate meteorological true wind can be computed.

Procedures are outlined to estimate true winds when existing datasets are lacking either the heading or course angles. The limitations of these techniques are evaluated by comparing the estimates to correctly computed true winds. Estimates computed using a heading to approximate the course of the vessel are found to be superior to those constructed using the course to approximate the heading. Large differences between the heading and course angles at low ship speeds make winds estimated using the course unreliable (direction errors exceeding 60°) for ship speeds less than 2.0 m s^{-1} . The threshold

where the direction difference between a course estimated and true wind reaches an acceptable level (i.e., $<10^\circ$) can be determined empirically and depends upon the ship, winds, and currents in the vessel's region of operation. These techniques produce true wind estimations from incomplete datasets. The range of conditions for which these techniques are valid is also examined.

2. Causes for inaccuracy

Inaccuracies in true winds result from many problems. Foremost are the confusion surrounding the definition of a true wind and the parameters needed to calculate that wind. There are also problems associated with the location and calibration of instruments, averaging, and recording of both wind and navigation measurements. We begin by defining all essential parameters related to true winds and their computation. Definitions typically used by meteorologists, oceanographers, and the merchant marine are discussed. We end this section with descriptions of typical problems found in the WOCE automated data.

a. Definitions

Navigational and wind parameters defined by meteorologists, oceanographers, and the merchant marines are outlined in Table 1. Each group defines a course over the ground, ship's speed over the ground, heading,

platform-relative wind, apparent wind, and true wind. For each measured parameter, the velocity and direction are referenced either to the ship or the fixed earth. The ship's directional reference frame has zero degrees at the bow of the vessel with angles increasing in a clockwise direction, while the earth's reference frame has true north corresponding to zero degrees with angles increasing in a clockwise direction. Each directional parameter has positive values defined with a direction *to* or *from* which the wind or ship is moving.

"Course over the ground (COG)" is defined as the direction (relative to true north) the vessel actually moves over the fixed Earth (Bowditch 1984).¹ Course, which differs from the COG, is defined as the "horizontal direction in which the vessel is steered" (Bowditch 1984). For the purpose of computing true winds, the COG is the essential measurement. The speed at which the vessel moves in the direction of the COG is known as the "speed over the ground (SOG)." The accuracy of the COG and SOG depends on the navigation system. The older NAVSAT (TRANSIT) system and the Global Positioning System (GPS) indicate different values for COG and SOG (Bowditch 1984). Of the 12 studied vessels that reported a COG, 8 used GPS, 1 utilized an integrated inertial navigation-GPS, and the other three systems were unknown.

"Heading" is defined as the direction *to* which the bow is pointing relative to true north (Bowditch 1984). Without this parameter, true winds cannot be computed. The heading is necessary to orient the shipboard anemometer's wind direction to true north. The heading and COG are *not* identical. For example, some research vessels can be propelled to astern, resulting in a COG that is 180° opposite the heading. Differences between COG and heading are also the result of currents, wind, and steering error (Bowditch 1984), and they are greatly reduced when the vessel is moving forward at a moderate or greater speed.

In addition to the ground referenced navigation (COG, SOG, and heading), a common practice is to measure the motion of the vessel through the water. This water-relative motion is a vector with components along and perpendicular to the axis of the ship. The fore to aft component of this motion (SOW_{FA}) is defined in all the observational datasets provided to WOCE-MET as the speed over the water. As defined, the SOW_{FA} is the speed of the vessel in the direction of the heading. The component of the water-relative motion along the beam of the ship can be measured by a two axis speed log; however, this component was only provided by 1 of the

20 studied vessels so we limit our discussion to the SOW_{FA} .

Most meteorologists, oceanographers, and members of the U.S. Merchant Marine use similar navigational definitions; however, differences in wind definitions are common. "Platform-relative wind" is defined as the wind vector measured relative to the ship. The only variation among meteorologists, oceanographers, and the merchant marine occurs with the platform-relative wind direction. Both meteorologists and the merchant marine report the direction *from* which the wind is blowing, while oceanographers usually report a direction *to* which the wind is blowing (Table 1).

In measuring a platform-relative wind, the "zero reference angle" is defined as the angle between the zero line of the wind vane and the bow of the vessel (measured clockwise from the bow). A zero reference angle becomes necessary when operational constraints preclude orienting the wind vane's zero line to the bow. For example, when mounting a vane high on a mast spar, it may be easier to orient the vane's zero line along the spar and then measure the angle between the spar and the fore to aft centerline of the vessel (hereafter, this direction will be referred to as the bow). Furthermore, many wind vanes have a potentiometer dead space at 360° (Fritschen and Gay 1979). In this case, orienting the vane with 180° toward the bow is practical as the majority of the platform-relative winds will be from the bow when the vessel is underway. The zero reference angle must be known to adjust the measured platform-relative winds to the ship's directional reference frame (i.e., bow = 0°). Wind vane installations are specific to each vessel or experimental design and must be known to correctly compute true winds.

The "apparent wind" is a wind vector with a speed referenced to the vessel and a direction referenced to true north. The apparent wind direction can be computed by adding the heading and zero reference angle to the platform-relative wind direction (the apparent wind speed equals the platform-relative wind speed). Meteorologists and the merchant marine again provide the direction *from* which the apparent wind blows while oceanographers typically record the direction *to* which the apparent wind blows (Table 1). The merchant marine also has an alternative definition for the apparent wind (Bowditch 1984) that is identical to the meteorological platform-relative wind. The purpose of this second definition is not clear in the context of motor-powered vessels and leads to obvious confusion.

The "true wind" is generically defined as a vector wind with a speed referenced to the fixed earth and a direction referenced to true north. The meteorological definition of true wind (Table 1) references the direction *from* which the wind is blowing (Huschke 1959), while oceanographers often reference the direction *to* which the wind is blowing (Hosom et al. 1995). The merchant marine utilizes two true wind definitions: one identical to the meteorological and the other with the true wind

¹ *The American Practical Navigator* is the primary resource for navigational methods utilized by the U.S. Merchant Marine. Mariners are trained using this text. The document was originally compiled by Nathaniel Bowditch in 1802 and has been updated periodically by the United States Navy Hydrographic Office since 1868.

direction reported relative to the bow of the ship (Bowditch 1984). The authors' experience with WOCE data indicates that the lack of a standard true wind definition or documentation of a specific definition is partially responsible for large discrepancies found in automated true wind data and in bridge measurements reported primarily by Volunteer Observing Ships (VOS; Pierson 1990; Wilkerson and Earle 1990; Kent et al. 1993).

b. Problems common to marine wind measurement

Additional problems with wind data from AWS-equipped research vessels are related to the wind instrumentation, approximations regarding navigation data, and calculation methodology. The calibration, orientation (see zero reference angle above), and location of the wind sensor are all very important to true wind calculations. Ideally, wind sensors are located in a region where the airflow is not seriously distorted by the measurement platform. In practice, disturbance of the flow at the instrument location by upwind or downwind structures (i.e., flow distortion) can only be minimized. The entire structure of the vessel and the mounting platform causes some degree of flow distortion; thus, the primary concern is siting the anemometer in a region that minimizes flow distortion caused by these structures (Kahma and Leppäranta 1981; Rahmstorf 1989; Yelland et al. 1994; Yelland et al. 1998). Recommended wind sensor locations range from high on the main superstructure to far out ahead of the bow. The solution attempted on several vessels (e.g., R/V *Wecoma*, R/V *Me-teor*) is to install multiple sensors and have an automated routine extract the data from the instrument best exposed to the wind.

Errors associated with the navigation assumptions are also troubling for true wind calculations. Three essential navigation parameters (COG, SOG, and heading) must be accurately recorded. Also essential are clear definitions of what navigation values have been measured. For example, simply reporting a "course" is ambiguous and can easily be mistaken to mean either the direction in which the vessel is steered, the course made good (Bowditch 1984), or the COG. Reporting only a vessel's "speed" causes similar confusion because the speed could be referenced to the water or the earth. Furthermore, if the navigation sensors are not properly calibrated (Hartten 1998), then use of the measurements in calculations will lead to erroneous true winds. Finally, some measure of the navigation data's quality is necessary as positions are frequently reported in the wrong hemisphere, over land, or at a distance too far removed from the previous position to represent a realistic ship movement. Poorly calibrated, missing, or incorrectly measured navigational parameters lead to errors in calculated true winds.

Finally, multiple methods for calculating a true wind are employed in a wide range of applications. For example, most merchant marine vessels use graphical cal-

culators, whereas research vessels often rely on a series of equations encoded in an AWS. In the absence of standard reporting, meteorologists, oceanographers, and members of the merchant marine tend to calculate and report true winds in the convention most suited to their operational needs. True winds are routinely exchanged without an explicit statement of the recording convention or calculation methodology. As a result, the differences in calculations and definitions are not known to the user of the true winds.

3. Meteorological true wind

For centuries, requirements for ship operation, and more recently operational weather forecasting, have relied on a knowledge of the meteorological true wind. The World Meteorological Organization (WMO) requires VOS to report true winds in the meteorological sense (WMO 1996). The authors recommend that the meteorological (first merchant marine) definition be used to record true winds on automated systems, including those on non-VOS ships. Alternatively, useful true winds can be computed if the recording convention is reported.

a. Correct computation

Calculating the meteorological true wind from a moving vessel requires the observed wind to be adjusted for the mean horizontal motion of the ship. For example, consider a woman facing forward on the bow of a stationary ship on a calm day. If the ship begins moving forward, the woman will feel a fresh wind (the apparent wind) on her face. The wind induced by the ship's motion (**M**) must be removed from the apparent wind (**A**) to compute a meteorological true wind (**T**),

$$\mathbf{T} = \mathbf{A} - \mathbf{M}. \quad (1)$$

The apparent wind is calculated by adding the heading and zero reference angle to the platform-relative wind direction, thereby orienting the wind measured on the vessel to true north. The motion-induced wind has the same magnitude as the course vector (**C**) with the opposite sign,

$$\mathbf{M} = -\mathbf{C}. \quad (2)$$

Note that **C** is the vector motion of the ship over the fixed earth (i.e., direction equals COG, magnitude equals SOG). From (1), a true wind results by adding the course vector to the apparent wind vector:

$$\mathbf{T} = \mathbf{A} - (-\mathbf{C}) = \mathbf{A} + \mathbf{C}. \quad (3)$$

In the example above, the breeze felt by the woman on the bow would be canceled by the vector addition of the forward motion of the vessel.

The computation of a true wind is often misinterpreted as removing the ship's course vector from the apparent wind vector. This error causes a distinct stair-

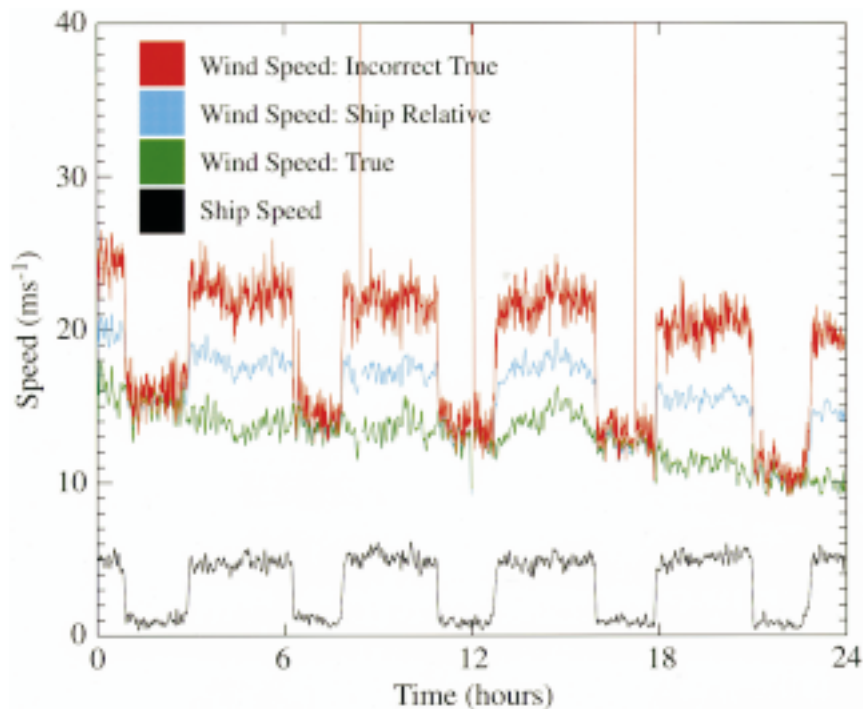

FIG. 1. Example of accurate true wind calculation (green) vs incorrect calculation (red) for the R/V *Knorr*. Note that both the platform-relative wind (blue) and the incorrect true wind have a signal of the ship's earth-relative speed (black).

step pattern (Fig. 1) in the incorrectly calculated true wind speed (red) that is associated with the ship's forward speed (black). In this case, the incorrectly calculated true wind speed differs from a correctly calculated true wind speed (green) by up to 8 m s^{-1} when the vessel is moving at speeds greater than 2 m s^{-1} . Similar stair-step patterns occur in true wind data when other 180° errors are recorded in the platform-relative wind data (e.g., failure to report an oceanographic convention or a wind vane installed with the zero reference toward the stern). In general, a 180° error yields wind speeds that differ from the correct true wind speed by less than or equal to double the ship's speed.

The computation of meteorological true winds using an automated system requires that the vector equations be broken down into components. A detailed methodology is presented in appendix A. Appendix B contains techniques to convert between meteorological, oceanographic, and merchant marine conventions.

b. Requirements for practical application

In many applications, from flux calculations to data ingestion in a general circulation model, it is necessary to have more information than the true wind speed and direction. For example, many applications require that the wind speed be adjusted to the meteorological standard height of 10 m above the surface. Other applications require winds relative to the surface current (e.g.,

scatterometry, stresses, forcing of ocean models), while meteorological forecasts require earth-relative winds. The calculation of surface fluxes (of momentum, sensible heat, and latent heat) and atmospheric stability require additional observations including the air temperature, the skin temperature of the water (approximated by the near surface temperature), and a measure of the humidity (Liu et al. 1979). Observations of pressure are also useful to convert typical humidity measurements to specific humidity, which is used in height adjustments and flux calculations.

In recent years, the influence of sea state on fluxes and drag coefficients has become of interest (Smith et al. 1992; Donelan et al. 1997; Bourassa et al. 1999). There is some controversy regarding the dependence on sea state. Several flux parameterizations require wave age or the phase speed of the dominant waves (e.g., Smith et al. 1992; Bourassa et al. 1999). Recently, the direction of the wind relative to the direction of wave propagation has been shown to have a large impact on the surface stress and drag coefficients (Donelan et al. 1997; Bourassa et al. 1999).

Essential metadata, such as the height of the sensors, should be recorded for use in height adjustment and the calculation of fluxes. In theory, the height of the temperature and humidity measurements must be the same, but these can differ from the height of the anemometer (Liu et al. 1979). In practice, the height of the temperature and humidity observations has little influence on

the height adjustment of winds; however, these heights can have a serious impact on the calculation of fluxes (e.g., stress and latent heat). In most cases, the lack of metadata prevents the accurate calculation of surface fluxes. One of the most common errors in 10-m wind speed is due to incorrect specification of anemometer heights. In several cases this height was given relative to the deck rather than relative to the water surface (since the waterline of vessels changes with the load, this error is understandable). Ideally, data records would include the height of the deck above sea level; however, such information is available from only very few highly specialized research vessels.

4. Evaluating the quality of wind data

Our experience has shown that missing data due to instrument malfunctions, encoding errors, approximations, and oversights are common occurrences in automated data. Techniques to retrieve useful true wind information from these data sets are discussed in section 5. Application of quality-control procedures to identify problems is an essential first step. In this section, quality-control methods discussed include automated and visual inspections for erroneous data values and the identification of errors due to a vessel's acceleration. A brief note is included concerning the unavoidable problem of flow distortion. After identifying problems with wind and navigation data, techniques for estimating true wind (section 5) can be applied to incomplete datasets.

a. Identifying erroneous values

WOCE-MET utilizes a two-step process to quality control both true wind data and the variables necessary to calculate a true wind (Smith et al. 1996). The first step is automated and identifies erroneous ship positions and physically unrealistic observations. A position check verifies that the latitude and longitude values are over water, while a speed check verifies that the vessel has not moved forward at a rate greater than 15 m s^{-1} . A range check of realistic wind directions (0° – 360°) and wind speeds ($<40 \text{ m s}^{-1}$) is also performed. This latter check may highlight realistic extreme winds; thus, WOCE-MET personnel visually verify all flags added by the automated quality control.

Visual inspection of the data, though time consuming, is essential. The analyst adds flags for spikes, known instrument malfunctions, discontinuities, and values that are highly inconsistent with the surrounding trend. This latter contingency requires knowledge of the behavior of wind data from vessels and is subjective. Automated tests for discontinuities and spikes are available (Vickers and Mahrt 1997), but we find visual inspection to be adequate. Based on 82 ship months of automated meteorological true winds, the two-level quality control applies flags to an average of 5% of wind speeds and 6% of wind directions. On some vessels, the visual in-

TABLE 2. The rms differences between collocated ship and NSCAT true winds for ship data with a 180° error in the platform wind and for the corrected true wind. Also presented is the improvement in the correlation coefficient for collocated wind speeds.

True wind	rms wind speed difference	rms wind direction difference	Correlation coeff. for wind speed
With 180° error	3.2 m s^{-1}	21°	0.51
Corrected	1.8 m s^{-1}	14°	0.89
Percent change	–44%	–33%	74%

spection determines that all true wind directions and speeds are incorrect. Removing or correcting these flagged true wind values is essential before performing any application using the data.

The two-level quality control employed by WOCE-MET has proven invaluable. For two of the four vessels reporting all values necessary to compute true winds, the visual inspection allowed the analyst to determine that the platform wind direction was reported opposite the desired meteorological direction. When problems of this type are located, the platform wind is corrected and new meteorological true winds are calculated. The impact of fixing 180° errors is evident (Table 2) when the true wind values are compared to independent wind measurements from the National Aeronautics and Space Administration (NASA) Scatterometer (NSCAT; Bourassa et al. 1997). Table 2 reveals that the correction of the 180° error decreased the root-mean-square (rms) difference between collocated (within 25 km and 20 min) NSCAT and ship winds by 44% for speed and 33% for direction. The correlation coefficient for collocated wind speed improves by 74%. Visual inspection of the wind data is necessary and in some cases leads to a much larger set of useable wind values.

b. Averaging techniques and acceleration problems

The choice of averaging techniques impacts the accuracy of true winds. Ideally, observations (platform–relative winds) would be made over short intervals and used to calculate true winds corresponding to those times. The true winds would then be averaged and stored. At this time observational equipment and data processing are equal to the task [e.g., the Tropical Atmosphere–Ocean (TAO) buoy array; Hayes et al. 1991]; however, this ideal is rarely achieved.

The averaging time for platform–relative winds should be sufficiently short so that navigational and ship–relative wind observations are approximately constant. The size of averaging periods depends on accuracy requirements and operational constraints for the vessel. For example, research vessels spend a relatively large fraction of their operating time accelerating or decelerating. It will be shown that these changes in velocity can be identified in 1-min averages; therefore, shorter averaging times (perhaps $<10 \text{ s}$) are recommended for

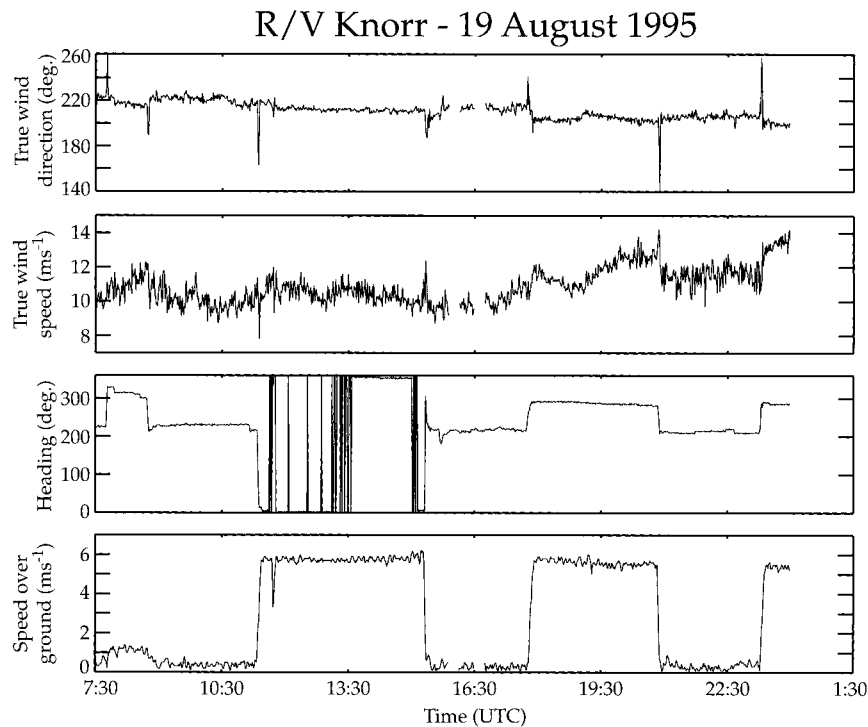

FIG. 2. Spikes that occur in true wind direction and speed caused by the acceleration of the vessel. Displayed are the true wind direction and speed, heading, and speed over the ground from the automated weather system on the R/V *Knorr* (0730–2359 UTC 19 Aug 1995).

the navigational parameters and platform–relative winds. The requirements for storage and postprocessing could be copious; therefore, we recommend that this averaging be processed by the shipboard instruments, and an average of the true winds (over 15–300 s) be recorded. A further advantage of averaging true winds as vectors, rather than speeds and directions, is the elimination of problems with the 360° – 0° breakpoint. At this time, such procedures are rarely implemented.

Typically, platform–relative winds and navigational parameters utilized in the true wind calculations (section 3a and appendix A) are averaged over intervals ranging from one minute to an hour. Since the true wind equations are nonlinear, they are accurate only when all the input parameters are approximately constant over the averaging period. When appropriate averaging cannot be applied, and the observations are too variable, the true winds should be flagged as suspect. One noticeable and regular manifestation of this problem occurs when research vessels accelerate or decelerate. The impact of changing ship velocities is examined for an Improved Meteorology system (Hosom et al. 1995) on the R/V *Knorr*, which records platform–relative winds in one minute intervals. These acceleration errors manifest themselves as spikes in the true wind speed and direction data (Fig. 2). The magnitude of the error in individual calculations is dependent on the rate of acceleration; however, for the R/V *Knorr* the spikes can approach 2 m s^{-1} and 60° .

We have found, empirically, that quality-control criteria can be based on the standard deviation of the ship's velocity (σ_v) determined from 1-min observations within a longer averaging period (6 min in the following example):

$$\sigma_v = \left\{ \frac{1}{N} \sum_{i=1}^N [(u_i - \bar{u})^2 + (v_i - \bar{v})^2] \right\}^{1/2}, \quad (4)$$

where N is the number of observations and the overbar indicates averages of these N observations. For many applications the uncertainty due to acceleration is relatively small and can be ignored. However, satellite measurements of the near surface winds by NSCAT are sufficiently accurate (Bourassa et al. 1997) that this additional uncertainty is apparent when comparing ship-based winds to remotely sensed winds. The impact of this criterion is shown in the mean and rms differences between winds from NSCAT and the R/V *Knorr*. Without this criterion, there are 18 collocations (closest observations within 25 km and 20 min) with a mean difference (satellite minus ship) of -0.8 m s^{-1} , and an rms difference of 2.0 m s^{-1} . When observations with $\sigma_v > 1.0 \text{ m s}^{-1}$ (12 collocations with accelerations that are considered too rapid and prolonged) are flagged and removed, the mean difference changes to 0.55 m s^{-1} , and the rms difference drops to 1.3 m s^{-1} . These findings are consistent with an assessment of the NSCAT-1 model function in comparisons with the National Data Buoy

TABLE 3. Based on 20 vessels equipped with automated wind systems, the number that report (✓) the parameters needed for computing a meteorological true wind or an estimate of the true wind (heading or course missing).

Platform relative wind	Heading	Course over ground	Speed over ground	Speed over water	Number of ships reporting
✓	✓	✓	✓	—	4
✓	—	✓	✓	—	8
✓	✓	—	—	✓	6

Center buoys by M. Freilich and R. S. Dunbar (1997, personal communication) and the TAO buoys by K. Kelly (1997, personal communication). The change in the mean is statistically significant, corresponding to 4.3 standard deviations of the mean. The almost 50% overestimation of the rms difference, prior to this quality-control criterion, shows that there are applications where changes in the vessel's velocity can result in substantial averaging-related errors in the calculated true winds.

c. Flow distortion

Another problem that occurs with ship-based winds is flow distortion. Structures (i.e., the entire ship, and to a lesser extent, the measuring device) cause air to deviate from the path it would take if the structures were not present. Flow distortion occurs in the wake of structures, around structures, and upwind of structures. The resulting change in wind characteristics (speed, direction, and the variation of these quantities) is highly dependent on shape of the vessel, instrument position, and wind direction relative to the vessel's heading. Recently, computational fluid dynamics has been successfully applied to correct for the impacts of flow distortion (Yelland et al. 1998). Other techniques are relatively simple; however, they are much more crude. The range of directions, over which the influence of flow distortion is a relatively strong function of platform-relative wind direction, can be estimated by binning the wind speed as a function of this direction (Thiebaut 1990). We have found a similar result with the variation in the wind speed. However, neither of these approaches indicates the impact of the flow distortion nor the angles at which the impact is a minimum. These techniques can only be used to isolate angles at which the impact of flow distortion is approximately constant, which can be advantageous for data analysis.

5. Estimating true winds from incomplete data

Incomplete observations from 16 of 20 studied vessels left only four with all values required to calculate meteorological true winds (Table 3). Consequently, we investigated methods for estimating meteorological true winds when some of the navigation parameters are missing. The two most common occurrences of missing nav-

igation data are vessels reporting only a COG and SOG (no heading) or a heading and SOW_{FA} (no COG; Table 3). In these cases, if the platform-relative winds and zero reference angle are known, estimates for the true winds can be made; however, the underlying assumptions can lead to serious errors. Empirical studies reveal the conditions under which these estimations are practical.

If the heading is missing, a true wind can be estimated by replacing the heading with the COG. This estimate is hereafter called a course-estimated wind. Thus, the apparent wind direction is calculated by summing the COG angle, zero reference angle, and platform-relative wind direction. The accuracy of this estimate is questionable at low ship speeds where the course-estimated wind direction (black, Fig. 3a) deviates wildly from the actual true wind (red).

The range of SOG where the course-estimated winds are valid can be determined empirically and depends upon the vessel and its region of operation. As an example, we determine this range using two vessels that reported all necessary values to WOCE-MET. Differences between the course-estimated and true wind direction are computed using quality controlled observations from the R/V *Thompson* (8.9 months) and the R/V *Knorr* (4.7 months). The direction differences are separated into 0.5 m s⁻¹ SOG bins and an rms difference is calculated for each bin. Rms differences and the number of values in each SOG bin, from 0 to 9 m s⁻¹, are presented for the R/V *Thompson* and R/V *Knorr* (Fig. 4). For low ship speeds (SOG < 2 m s⁻¹), both vessels exhibit rms difference near or greater than 60°. Direction differences drop below 20° when the SOG exceeds 2.5 m s⁻¹ for the *Thompson* and 4.0 m s⁻¹ for the *Knorr*. Determining a threshold SOG for which the rms difference is within an acceptable range is user dependent. For an rms wind direction difference less than 10°, the threshold SOG is 3.5 m s⁻¹ for the *Thompson* and 5 m s⁻¹ for the *Knorr* (Fig. 4). In summary, the primary limitation of the course-corrected wind estimates is that they are sensitive to the SOG; becoming unreliable at low ship speeds.

Inaccuracies in the course-estimated winds are directly related to measuring only SOG and COG without a heading. Eight of twenty studied vessels relied solely on single receiver GPS systems to measure their geographical position and to provide values of SOG and COG. A single receiver GPS is not designed to measure heading; therefore, it cannot always estimate the heading with sufficient accuracy. This problem is exaggerated at low ship speeds when current and wind forces on the ship can cause large differences between heading and COG (Figs. 3b,c). As a result, the true winds reported by these eight vessels are course-estimated winds. Furthermore, errors in course-estimated winds are increased if the latitude and longitude are not recorded to at least the thousands decimal place. The ability to measure the orientation of the vessel using only

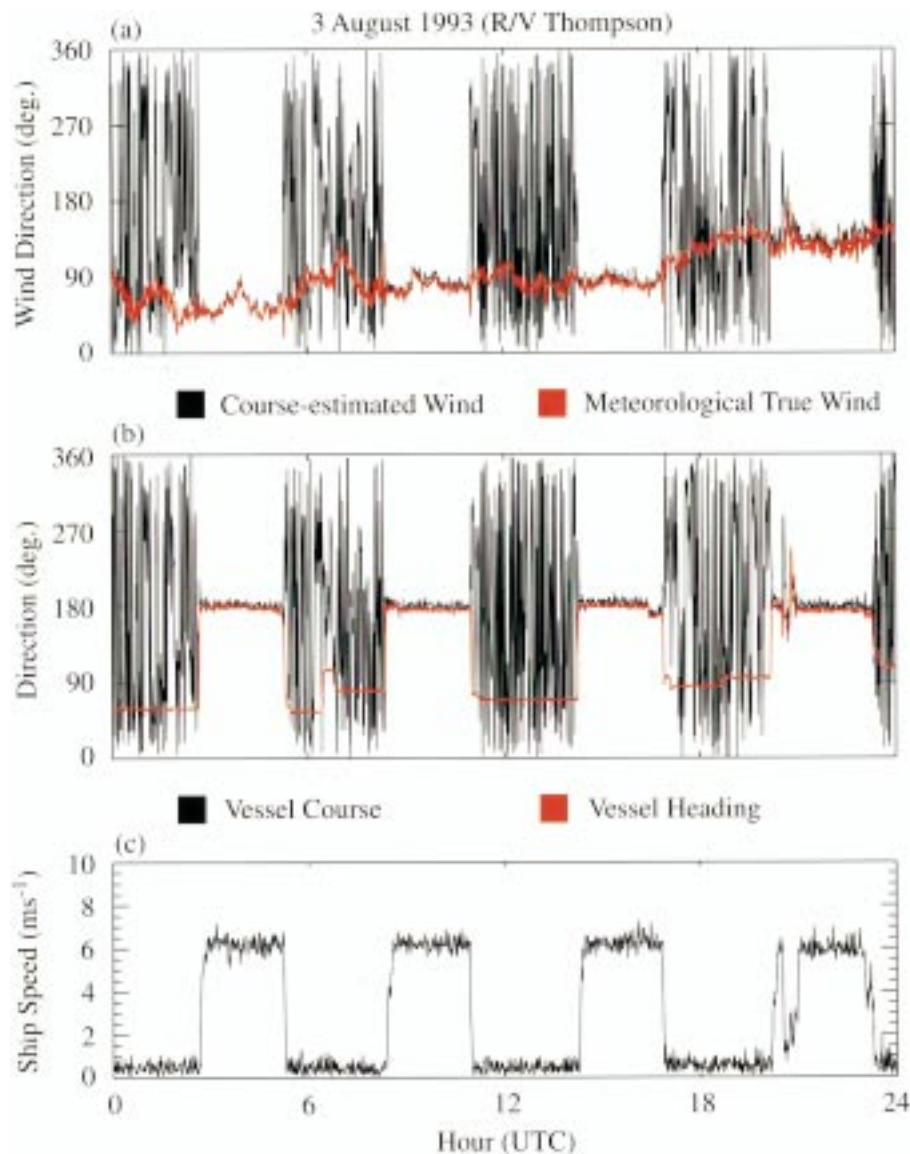

FIG. 3. Time series plots of (a) course-estimated (black) vs meteorological true (red) wind direction, (b) vessel course (black) vs heading (red), and (c) vessel speed over the ground from the R/V *Thompson* (3 Aug 1993).

GPS technology can be improved using a multiple receiver GPS, but for vessels with single receiver GPS we recommend the addition of a gyrocompass to record the heading.

When a vessel relies on navigation without the aid of technology referenced to the fixed earth, it is common practice to measure only the heading of the vessel and the SOW_{FA} . When only heading and SOW_{FA} are measured, an earth-relative wind cannot be computed. Instead, an estimate referenced to the water can be created by replacing the course vector in (3) with a heading vector, \mathbf{H} , where the $|\mathbf{H}|$ equals SOW_{FA} and the direction of \mathbf{H} is the direction the bow is pointing (referenced to true north). Unlike the course-estimated winds, fre-

quency diagrams (not shown) of this heading-estimated wind minus the meteorological true wind reveal differences with no dependence on forward ship speed. Instead, the heading-estimated wind deviates from a true wind only when the SOW_{FA} and SOG are different from one another. A time series plot for 12 h of wind data from the R/V *Knorr* illustrates the differences that can occur (Fig. 5). In this case a 2 m s^{-1} difference in the SOW_{FA} and SOG (Fig. 5b) results in an average direction error of 25° (Fig. 5a). Variations between the SOW_{FA} and SOG are related to currents.

In summary, an examination of a total of 13.6 ship months of automated observations from two vessels shows that, when computation of a meteorological true

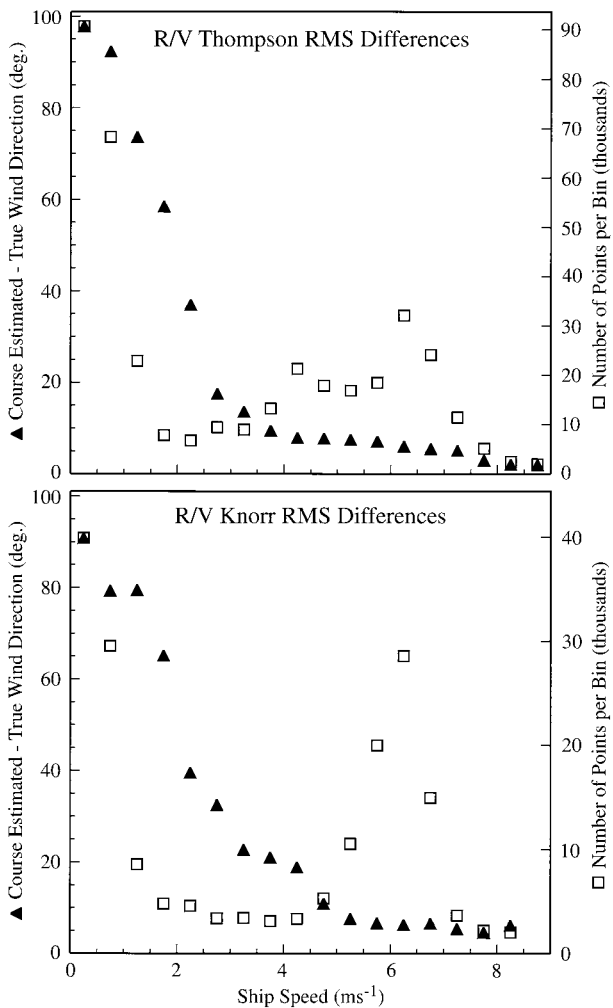

FIG. 4. Rms differences of course-estimated minus true wind direction (filled triangles) from the R/V *Thompson* and R/V *Knorr*. Rms differences are calculated for 0.5 m s^{-1} bins of the vessel's speed over the ground using the absolute value of the wind direction differences (i.e., range 0° – 180°). The number of values in each bin (open squares) are presented in units of thousands.

wind is not possible, heading-estimated winds are superior to course-estimated winds. The accuracy of the heading-estimated winds is limited by the difference between SOW_{FA} and SOG. When these speeds are not significantly different, the heading-estimated and true wind directions are nearly identical. When an operator only records the SOG and COG, the potentially large differences between the COG and heading, at low ship speeds, result in large differences between course-corrected and true winds.

6. Summary and recommendations

Problems in computing true winds from automated systems have been identified and solutions are demonstrated. Principal problems include confusion related to inconsistencies in definitions for true wind used by

meteorologists, oceanographers, and the U.S. Merchant Marine, and the lack of standard reporting of both wind and navigation measurements (or the convention used). The primary recommendation is setting a standard for reporting the six values needed to compute a true wind: COG, SOG, heading, zero reference, and platform-relative wind direction and speed. Additional metadata, especially the height of the wind sensor relative to the water surface, must also be reported.

Accurate meteorological true winds result from the vector sum of the ship's motion relative to the fixed earth and the apparent wind. Details of this calculation are outlined in appendix A. Conversions from the meteorological true wind to oceanographic and merchant marine definitions are detailed in appendix B. The true wind calculations and conversions presented can be applied to AWS and nonautomated wind measurements.

True winds must be quality controlled before application to identify errors. At WOCE-MET, a two-level quality-control system composed of an automated pre-processor and a detailed visual examination has proven effective in identifying both minor (e.g., out of range values, spikes, ship acceleration) and major (e.g., incorrectly oriented platform-relative wind) errors.

When dealing with incomplete datasets (e.g., approximately 80% of examined AWS data), true winds can be estimated within determinable limitations. A better estimate for a wide range of forward ship speeds can be obtained when a heading and SOW_{FA} are measured, rather than an estimate derived from SOG and COG when no heading is available. The heading-estimated wind varies from a true wind only when the SOW_{FA} and SOG are significantly different. The uncertainty in course-estimated winds has a strong dependency on the forward ship speed. Empirical studies show course-estimated wind directions to be unreliable ($\text{rms} > 60^\circ$) when the $\text{SOG} < 2.0 \text{ m s}^{-1}$. Useful estimates can be obtained at higher ship speeds; however, the threshold SOG depends upon the ship, the vessel's operating area, and the user's desired level of uncertainty.

The following recommendations are made for future automated observing systems, thereby avoiding the need to estimate the true winds. The standard set of measurements needed to compute a true wind (i.e., SOG, COG, heading, wind relative to the vessel) *must* all be logged at the same frequency as the standard meteorological variables. Averaging should be applied to true winds calculated from shorter term (0.5–10 s) observations. Essential metadata (e.g., zero reference, instrument heights) must be reported. When it is essential that measurements be collected without losing data, redundancy should be planned for both the navigation and wind measurements. When an instrument fails in a redundant system, alternate measurements can be used in the computation of true wind or an estimate of the true wind can be created. For example, 3 years of AWS wind data on one studied vessel were lost due to the failure of a navigational compass in the wind sensor. If the

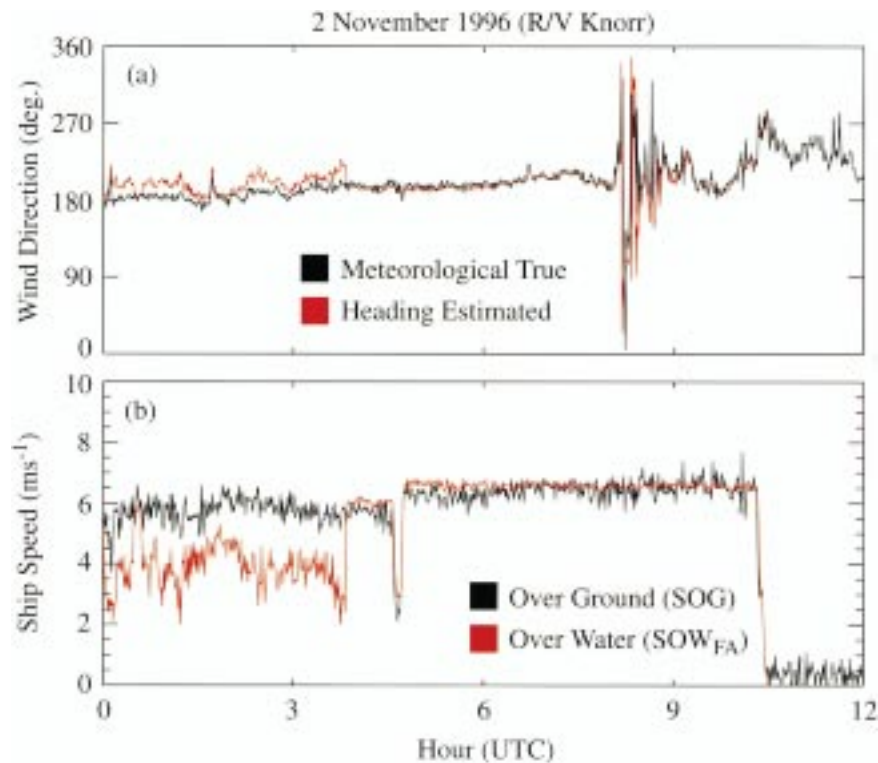

FIG. 5. Time series plots of (a) heading-estimated (red) vs meteorological true (black) wind direction and (b) vessel speed over the water (red) vs the speed over the ground (black) from the R/V *Knorr* (2 Nov 1996). Note that the speed over the water drops out after 1030 UTC due to an instrument malfunction.

ship’s gyrocompass heading had been archived in the meteorological data stream, the loss could have been avoided. If the marine community utilizes the techniques and recommendations herein, a superior quality of high temporal resolution true wind observations can be computed from automated platforms on vessels at sea.

Acknowledgments. The authors wish to thank Dr. Leslie Hartten for her comments on ship wind measurements, Ms. Masha A. Medvedeva for her contributions to the wind analysis, and the anonymous reviewers for their constructive comments. The authors also acknowledge the professional support of Dr. David M. Legler. We further express our gratitude to the personnel both at sea and on shore that provided the data for this study.

COAPS receives its base funding from the Physical Oceanography Section of the Office of Naval Research. WOCE-MET and this research are funded by the Physical Oceanography Section of the National Science Foundation, Grant OCE-314515, and from the NASA JPL NSCAT Project, Contracts 957649 and 980646.

APPENDIX A

Details for Automated Calculation of True Winds

This appendix is a tutorial containing algorithms for calculating meteorological true winds from ship obser-

ventions. The mathematics and all necessary variables (Table A1) are discussed and an example provided.

All calculations are performed in the mathematical coordinate system, which has an angle of zero degrees on the positive *x*-axis with angles increasing in a counterclockwise direction. Each vector direction, originally defined using the meteorological conventions (Table 1), is converted to mathematical coordinates prior to other calculations (see Table B1 to convert from other conventions). Primes (') denote values in math coordinates.

Platform-relative winds (**P**) and navigational data are used to calculate apparent (**A**) and true (**T**) winds. The direction of the apparent wind in the math coordinates is

$$A'_\theta = 270^\circ - (h_\theta + R_\theta + P_\theta), \quad (A1)$$

where *h* is the vessel’s heading, *R* is the zero reference, and the subscript *θ* designates an angle. The magnitude of **A** is the same as the magnitude of **P**. Use of the heading instead of the COG in (A1) is essential because the bow is rarely oriented in the direction of ship motion over the fixed earth. As an example, consider the bow of a ship is oriented directly to the east (*h*_θ = 90°). If there is either a strong current or wind from the north, then the vessel will be pushed to the south, resulting in a COG greater than 90°.

Most ships utilize the bow as the zero reference for the platform-relative wind, but there are exceptions to

TABLE A1. Variables needed for true wind vector (**T**) calculation.

Parameter	Type	Symbol	Direction reference frame	Velocity reference frame
Ship heading	Scalar	h_θ	True north	—
Ship course over ground	Vector	C	True north	Fixed earth
Platform-relative wind (direction <i>from</i> which wind is blowing)	Vector	P	Zero reference on ship	Ship
Zero reference angle for platform-relative wind	Scalar	R_θ	Bow of ship	—

this practice. When another point on the ship is used as a zero reference for the wind vane, the angle between this reference and the bow (R_θ in Fig. A1) must be included in (A1) to correctly calculate the apparent wind direction.

The COG of the vessel (C_θ) in math coordinates is

$$C'_\theta = 90^\circ - C_\theta. \tag{A2}$$

The true wind is then computed by summing the vector components of the apparent wind and ship motion:

$$T_u = T'_u = |\mathbf{A}| \cos(A'_\theta) + |\mathbf{C}| \cos(C'_\theta), \tag{A3a}$$

$$T_v = T'_v = |\mathbf{A}| \sin(A'_\theta) + |\mathbf{C}| \sin(C'_\theta), \tag{A3b}$$

where positive T_u and T_v are the eastward and northward components of the true wind in the earth reference frame. The true wind speed ($|\mathbf{T}|$) and direction (T_θ) can then be calculated:

$$|\mathbf{T}| = (T_u^2 + T_v^2)^{1/2} \tag{A4}$$

and

$$T_\theta = 270^\circ - \text{atan}\left(\frac{T_v}{T_u}\right). \tag{A5}$$

The 270° in (A5) converts the value of $\text{atan}(T_v T_u^{-1})$ to a direction *from* which the wind is blowing (meteo-

logical convention) in the earth coordinate system. For (A5) to return a correct angle, the atan function must have a range from -180° to 180° to determine the vector's trigonometric quadrant (e.g., the FORTRAN “atan2” function). Also, any program using (A5) must have a check to avoid dividing by zero.

As an example calculation consider a ship (Fig. A2) with a heading (h_θ) of 30.0° and a COG (C_θ) of 45.0° both referenced to true north (0° in a fixed earth reference frame). The vessel is travelling at a SOG ($|\mathbf{C}|$) of 5.0 m s^{-1} . The platform-relative wind, with the bow as the zero reference angle ($R_\theta = 0.0^\circ$), is blowing *from* a direction (P_θ) of 250.0° with a magnitude ($|\mathbf{P}|$) of 10.0 m s^{-1} . The conversion to math coordinates using (A1) and (A2) results in $A'_\theta = 350.0^\circ$ and $C'_\theta = 45.0^\circ$. Computing the true wind components using (A3a) and (A3b) gives a $T_u = 13.4 \text{ m s}^{-1}$ and a $T_v = 1.8 \text{ m s}^{-1}$. The meteorological true wind speed from (A4) is 13.5 m s^{-1} and the true wind direction, (A5), is blowing *from* 262.3° .

Table A2 provides sample input and the output that should be returned from a meteorological (and first Merchant Marine) true wind algorithm. Any algorithm used to calculate true winds should duplicate these results.

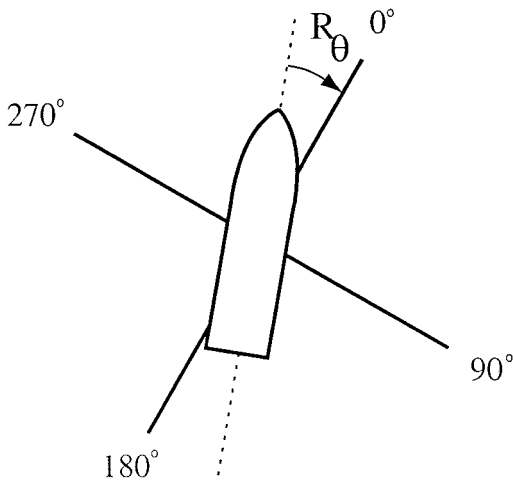

FIG. A1. Platform-relative coordinate system with a zero reference angle, R_θ , not oriented to the bow.

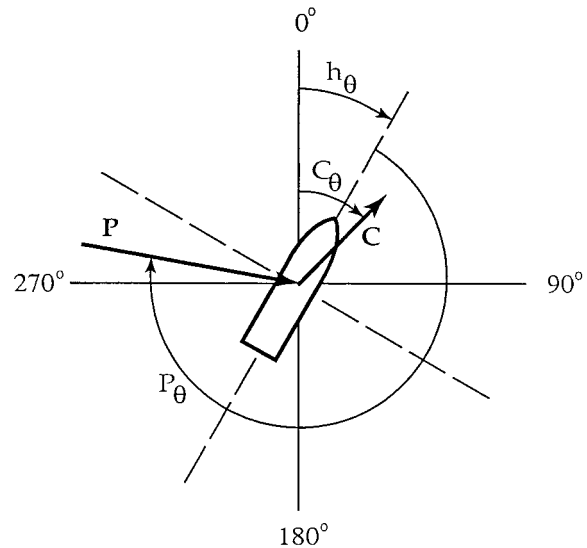

FIG. A2. Schematic representation of the vectors and angles involved in the true wind problem. See text for explanation of symbols.

TABLE A2. Sample input and output for the true wind calculation. For simplification, the zero reference is the bow of the vessel ($R_\theta = 0^\circ$). The table is divided into input (lightface) and output (bold) values. Note that both the apparent and the true wind directions are referenced to true north, and all wind directions are angles *from* which the wind is blowing. Also the WMO convention is utilized for calm (direction = 0°) and north winds (direction = 360°).

Vessel course over the ground ($^\circ$)	Vessel speed over the ground ($m\ s^{-1}$)	Vessel heading ($^\circ$)	Platform wind direction ($^\circ$)	Platform and apparent wind speed ($m\ s^{-1}$)	Apparent wind direction ($^\circ$)	True wind direction ($^\circ$)	True wind speed ($m\ s^{-1}$)
0.0	0.0	0.0	90.0	5.0	90.0	90.0	5.0
0.0	0.0	90.0	90.0	5.0	180.0	180.0	5.0
0.0	5.0	0.0	360.0	5.0	360.0	0.0	0.0
0.0	5.0	0.0	0.0	0.0	0.0	180.0	5.0
180.0	5.0	180.0	180.0	5.0	360.0	360.0	10.0
90.0	5.0	90.0	90.0	5.0	180.0	225.0	7.1
90.0	5.0	45.0	135.0	5.0	180.0	225.0	7.1
225.0	5.0	225.0	270.0	5.0	135.0	90.0	7.1
270.0	3.0	270.0	90.0	4.0	360.0	36.9	5.0
0.0	0.0	0.0	0.0	0.0	0.0	0.0	0.0

FORTRAN, C, and Interactive Data Language (IDL) routines for computing meteorological true winds are available at the URL: <http://www.coaps.fsu.edu/WOCE>.

APPENDIX B

Conversions between Different Conventions

As previously stated, the meteorological, oceanographic, and U.S. Merchant Marine conventions are different when defining true wind vectors. In the meteorological convention, wind direction is defined as the direction *from* which the wind is blowing in the earth reference frame. The merchant marine has an identical convention, but they also define a true wind with a direction referenced to the bow of the ship. In the oceanographic convention, wind direction is defined with a direction *toward* which the wind is blowing. This confusion presents problems when using true wind data. Table B1 provides the conversions between each of the conventions. After all direction conversions, the modulus of the returned value must be taken with respect to 360° to ensure a direction between 0° and 360° .

REFERENCES

Bourassa, M. A., M. H. Freilich, D. M. Legler, W. T. Liu, and J. J. O'Brien, 1997: Wind observations from new satellite and research vessels agree. *Eos, Trans. Amer. Geophys. Union*, **78** (51), 597–602.

—, D. G. Vincent, W. L. Wood, 1999: A flux parameterization including the effects of capillary waves and sea state. *J. Atmos. Sci.*, **56**, 1123–1139.

Bowditch, N., 1984: *American Practical Navigator: An Epitome of Navigation*. Defense Mapping Agency, 1414 pp.

Donelan, M. A., W. M. Drennab, and K. B. Kataros, 1997: The air-sea momentum flux in conditions of wind sea and swell. *J. Phys. Oceanogr.*, **27**, 2087–2099.

Fritschen, L. J., and L. W. Gay, 1979: *Environmental Instrumentation*. Springer-Verlag, 216 pp.

Hartten, L. M., 1998: Reconciliation of surface and profiler winds at ISS sites. *J. Atmos. Oceanic Technol.*, **15**, 826–834.

Hayes, S. P., L. J. Mangum, J. Picaut, A. Sumi, and K. Takeuchi, 1991: TOGA-TAO: A moored array for real-time measurements in the Tropical Pacific Ocean. *Bull. Amer. Meteor. Soc.*, **72**, 339–347.

Hosom, D. S., R. A. Weller, R. E. Payne, and K. E. Prada, 1995: The IMET (Improved Meteorology) ship and buoy systems. *J. Atmos. Oceanic Technol.*, **12**, 527–540.

Huschke, R. E., Ed., 1959: *Glossary of Meteorology*. American Meteorological Society, 638 pp.

TABLE B1. Conversion table to change between conventions for apparent and true wind directions. Note that the merchant marine utilizes two definitions for apparent and true wind (Table 1). The first merchant marine definitions are identical to those used in meteorology and should be treated identically [merchant marine (1) = meteorology] when using this conversion table. The merchant marine listings in this table refer to the second (2) apparent and true wind definitions from Table 1. After each direction conversion, a modulus with respect to 360° must be performed to ensure a value in the range of 0° – 360° .

Given	Meteorology → Oceanography	Oceanography → Meteorology
Apparent wind	Add 180°	Add 180°
True wind	Add 180°	Add 180°
Given	Meteorology → Merchant Marine (2)	Merchant Marine (2) → Meteorology
Apparent wind	Subtract heading of ship	Add heading of ship
True wind	Subtract heading of ship	Add heading of ship
Given	Merchant Marine (2) → Oceanography	Oceanography → Merchant Marine (2)
Apparent wind	Add heading of ship and add 180°	Subtract heading of ship and add 180°
True wind	Add heading of ship and add 180°	Subtract heading of ship and add 180°

- Kahma, K. K., and M. Leppäranta, 1981: On errors in wind speed observations on R/V *Aranda*. *Geophysica*, **17**, 155–165.
- Kent, E. C., P. K. Taylor, B. S. Truscott, and J. S. Hopkins, 1993: The accuracy of Voluntary Observing Ships' meteorological observations—Results of the VSOP-NA. *J. Atmos. Oceanic Technol.*, **10**, 591–608.
- Liu, W. T., K. B. Katsaros, and J. A. Businger, 1979: Bulk parameterization of air–sea exchanges of heat and water vapor including the molecular constraints at the interface. *J. Atmos. Sci.*, **36**, 1722–1735.
- Pierson, W. J., Jr., 1990: Examples of, reasons for, and consequences of the poor quality of wind data for the marine boundary layer: Implications for remote sensing. *J. Geophys. Res.*, **95**, 13 313–13 340.
- Rahmstorf, S., 1989: Improving the accuracy of wind speed observations from ships. *Deep-Sea Res.*, **36**, 1267–1276.
- Smith, S. D., and Coauthors, 1992: Sea surface wind stress and drag coefficients: the HEXOS results. *Bound.-Layer Meteor.*, **60**, 109–142.
- Smith, S. R., C. Harvey, and D. M. Legler, 1996: Handbook of quality control procedures and methods for surface meteorology data. WOCE Rep. 141/96, COAPS Rep. 96-1, 56 pp. [Available from WOCE Data Assembly Center, COAPS, The Florida State University, Tallahassee, Florida, 32306-2840.]
- Thiebaut, M. L., 1990: Wind tunnel experiments to determine correction functions for shipborne anemometers. Canadian Contractor Rep. Hydrography and Ocean Sciences 36, 57 pp. [Available from Bedford Institute of Oceanography, Halifax, Nova Scotia, B3J 2S7 Canada.]
- Vickers, D., and L. Mahrt, 1997: Quality control and flux sampling problems for tower and aircraft data. *J. Atmos. Oceanic Technol.*, **14**, 512–526.
- Wilkerson, J. C., and M. D. Earle, 1990: A study of differences between environmental reports by ships in the Voluntary Observing Program and measurements from NOAA buoys. *J. Geophys. Res.*, **95**(C3), 3373–3385.
- World Meteorological Organization, 1996: Guide to meteorological instruments and methods of observation. WMO Rep. 8.
- Yelland, M. J., P. K. Taylor, I. E. Consterdine, and M. H. Smith, 1994: The use of the inertial dissipation technique for shipboard wind stress determination. *J. Atmos. Oceanic Technol.*, **11**, 1093–1108.
- , B. I. Moat, P. K. Taylor, R. W. Pascal, J. Hutchings, and V. C. Cornell, 1998: Wind stress measurements from the open ocean corrected for airflow distortion by the ship. *J. Phys. Oceanogr.*, **28**, 1511–1526.