



**Kipp &
Zonen**

INSTRUCTION MANUAL

CV²

VENTILATION UNIT



0349 200

**Reading this entire manual is recommended for full
understanding of the use of this product**



The exclamation mark within an equilateral triangle is intended to alert the user to the presence of important operating and maintenance instructions in the literature accompanying the instrument.

Should you have any comments on the product or this manual we will be pleased to receive them at:

Kipp & Zonen B.V.
Röntgenweg 1 2624 BD Delft Holland
P.O. Box 507 2600 AM Delft Holland
Phone +31 (0)15 2698000
Fax +31 (0)15 2620351
E-mail info.holland@kippzonen.com

Kipp & Zonen reserve the right to make changes in the specifications without prior notice.

WARRANTY AND LIABILITY

Kipp & Zonen guarantees that the product delivered has been thoroughly tested to ensure that it meets its published specifications. The warranty included in the conditions of delivery is valid only if the product has been installed and used according to the instructions supplied by Kipp & Zonen. User made modifications can affect the validity of the CE declaration.

Kipp & Zonen shall in no event be liable for incidental or consequential damages, including without limitation, lost profits, loss of income, loss of business opportunities, loss of use and other related exposures, however caused, arising from the faulty and incorrect use of the product.

COPYRIGHT® 2004 KIPP & ZONEN

All rights reserved. No part of this publication may be reproduced, stored in a retrieval system or transmitted in any form or by any means, without permission in written form from the company.

Manual version 1203



Declaration of Conformity

According to EC guideline 89/336/EEC 73/23/EEC

We **Kipp & Zonen B.V.**
Röntgenweg 1
2624 BD Delft

Declare under our sole responsibility that the product

Type: **CV 2**
Name: **Ventilation unit**

To which this declaration relates is in conformity with the following standards

Immissions EN 50082-1 Group standard

Emissions EN 50081-1 Group standard
EN 55022

Safety standard IEC 1010-1

Following the provisions of the directive



B.A.H. Dieterink
President
KIPP & ZONEN B.V.

IMPORTANT USER INFORMATION.....	1
CE DECLARATION OF CONFORMITY	2
1. GENERAL INFORMATION.....	5
2. DELIVERY COMPLETE VENTILATION SYSTEM CV 2.....	7
3. SPECIFICATIONS CV 2	9
4. INSTALLATION OF THE CV 2	11
4.1 General.....	11
4.2 Measuring global radiation	12
4.3 Measuring diffuse radiation	13
5. INSTALLATION OF THE POWER SUPPLY FOR CV 2.....	15
6. MAINTENANCE AND OPERATING	17
7. TROUBLE SHOOTING	19
8. PART NUMBERS / SPARE PARTS / OPTIONS	21

1. GENERAL INFORMATION

The CV 2 ventilation unit is meant for ventilating solar radiation sensors and can be used outdoors under all weather conditions. The CV 2 is available with and without heater. An optional power supply can order separately.

The reliability and accuracy of solar radiation measurement can be improved by using artificial ventilation.

The main advantages of ventilating are:

1. Prevention of precipitation of dew and frost which otherwise would disturb the measurement.
2. Suppression of the infrared offset, which is produced e.g. by cooling down of the glass domes under calm clear sky conditions.

Under extreme conditions, it can be necessary to heat the ventilation air. If the temperature of the ventilation air does not exceed the temperature of ambient air by 1 K, offset problems are not significant.

The ventilation system CV 2 is meant to be used with the Kipp & Zonen pyranometers (CM 11, CM 6B, CM 21 and CM 22) and with radiation sensors with equal dimensions like the pyrgeometers (CG 1 and CG 4) and the UV-radiometers (CUVA 1, CUVB 1, CUV 3).

The CV 2 can be ordered with or without heater. The optional power supply can be used for both versions.

The ventilator of the CV 2 must run continuously. The heating can be connected for 5 or 10 Watt. Without heating the temperature of the instrument is maintained near to that of ambient air.

The ventilation unit is suited for placement on the 2AP Tracking system.

The ventilation system does not prevent the dome to become filthy.

The ISO Technical Report 9901 "Solar Energy - Field Pyranometers Recommended Practice For Use" contains an informative chapter on ventilation systems in general.

2. DELIVERY COMPLETE VENTILATION SYSTEM CV 2

CV 2 with heater	0349 901
Power supply for CV 2 (with heater)	0349 401
2 x bolt M6 x 90	2146 824
2 x bolt M5 x 50	0015 620
2 x nylon insulator	2147 249
2 x special screw	0015 621
2 x nut M6	6464 006
2 x lock washer M6	6487 006
2 x washer M6	6476 506
Instruction manual	0349 200

3. SPECIFICATIONS CV 2

Ventilation power	5 Watt continuously
Heating (optional)	5 and 10 Watt
Ambient operating temperature	-30 to +70 °C
Air temperature rise caused by CV 2	< 0.25 K @ 0 Watt (blower only) < 0.5 K @ 5 Watt (heater) < 1 K @ 10 Watt (heater)
Offset caused by heater (10 W)	< 1 W/m ² using Pyranometer CM 11
Cable length	10 m.
Power required	12 Volt DC, 1,25 A (with 10 W heater)

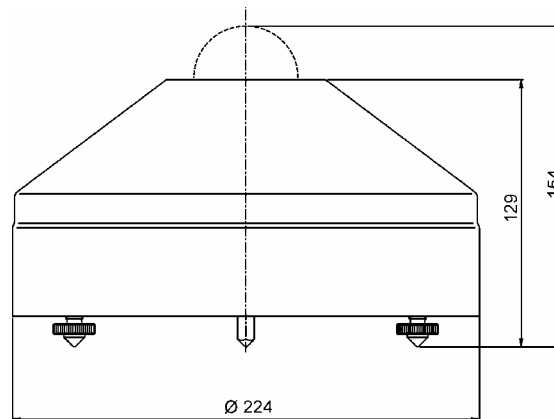

Figure 3.1 CV 2 outline dimensions in mm

4. INSTALLATION OF THE CV 2

4.1 General

The installation of a radiometer in the blower unit can be seen in figure 4.1.1. The radiometer feet have to be removed first.

The radiometer is mounted flat on the mounting plate inside the CV 2 with the 2 special M5 x 50 screws and the 2 nylon insulator rings (all included in delivery of CV 2)

Once the radiometer is mounted inside the ventilation unit, the CV 2 can be levelled using the spirit level of the radiometer and the adjustable feet of the CV 2. After levelling the CV 2 can be fixated to the floor or plate using the 2 M6 x 90 screws. The cable of the radiometer can be slit through the opening of the side of the CV 2 base plate.

At this point the rubber ring can be mounted in the groove on the side of the base plate. After that the cover can be put over the inner part of the CV 2 and the radiometer. The cover must be lowered until the narrow part of the cover is over the rubber ring.

The rubber ring is covered with grease to prevent sticking to the inside of the cover.

Mount the 2 special screws to lock the cover (figure 4.1.2).

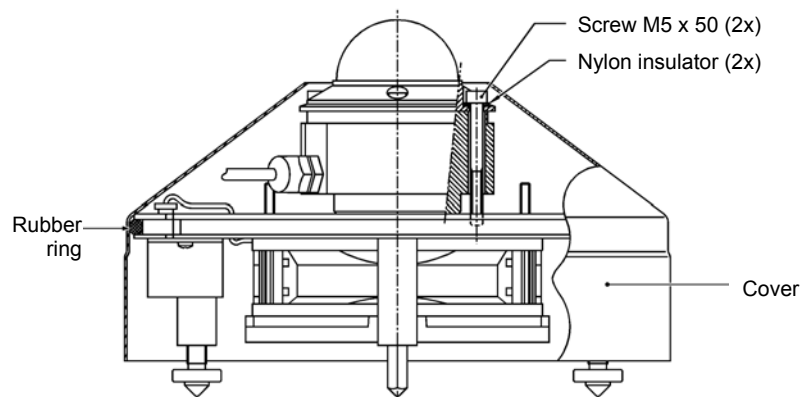

Figure 4.1.1 Installation of a radiometer in the blower unit

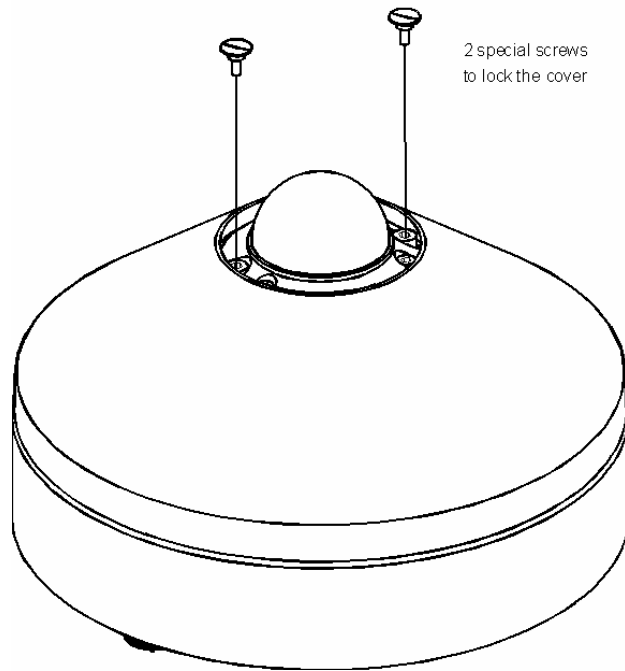

Figure 4.1.2 The 2 special screws to lock the cover.

4.2 Measuring global radiation

The blower unit can be installed on a flat plate, using the CV 2 levelling screws. Figures 4.2.1 and 4.2.2 refer to this situation. If problems with snow build-up are expected, a hole can be made in the plate directly under the ventilator. Make sure this hole does not exceed $\varnothing 120$ mm!

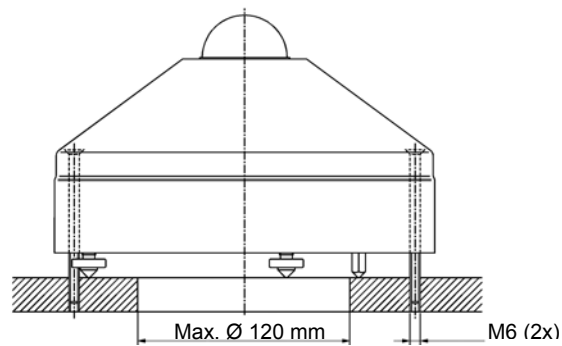

Figure 4.2.1 Blower unit on a flat plate

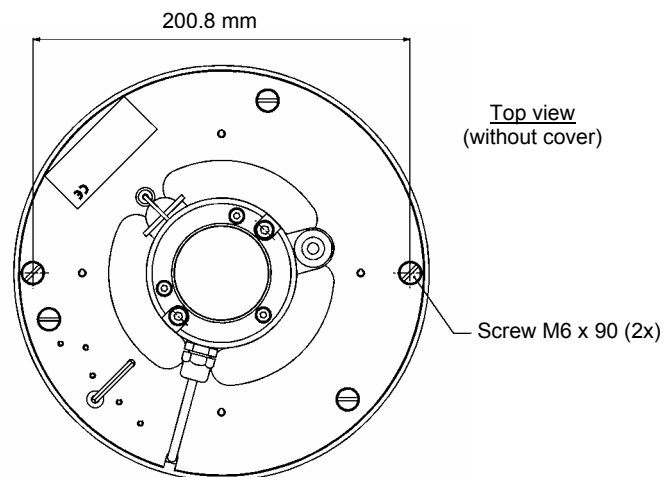

Figure 4.2.2 Footprint of the CV 2 for mounting on a plate

4.3 Measuring diffuse radiation

The blower unit can be mounted on the Kipp & Zonen 2AP tracking system (see figure 4.3.1)

No special precautions are necessary. Instead of the radiometer support the CV 2 will give the radiometer the correct height. The mounting holes to fixate the CV 2 are present on the 2AP mounting plate.

Further details on how to mount the CV 2, radiometer combination on the tracker will be given in the 2AP manual.

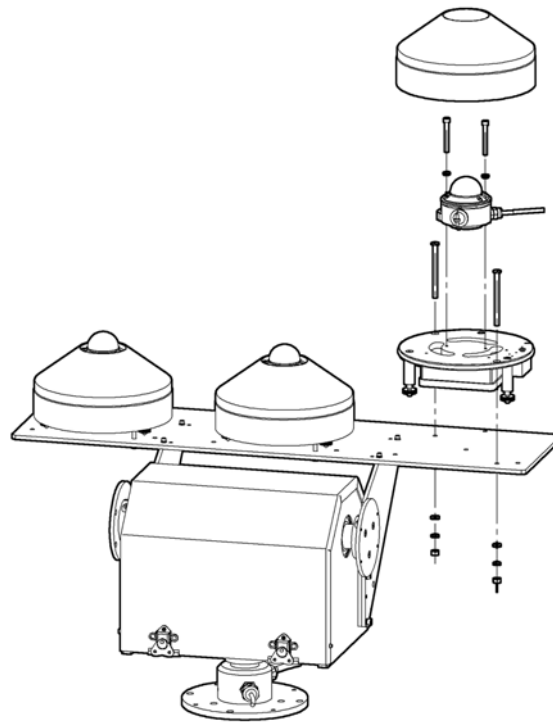

Figure 4.3.1 CV 2 installed on Kipp & Zonen Solar Tracker

5. INSTALLATION OF THE POWER SUPPLY FOR CV 2

The optional power supply unit (figure 5.1) is meant for indoor installation only. The dimensions are (W x D x H) 134 x 80 x 53,5 mm.

The power supply unit requires 115 or 230 VAC as input.

The output is 12 VDC at 2,5 A. Therefore when necessary this unit can supply the power for two CV 2's.

The power supply is a switching type that automatically adapts to the supplied voltage. To connect the power supply to a normal mains outlet the changeable mains connector can be selected from one of the following 4 supplied types:

- European style type
- UK style type
- USA style type

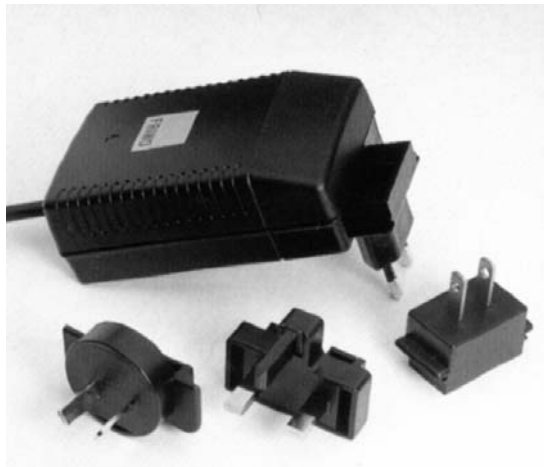

- Australian style type

Figure 5.1 Power supply unit for CV 2

The CV 2 has a 10 meter 4 wire shielded cable to connect to the power supply. The connection between the CV 2 cable and the adapter cable can be made with any standard connection terminal block (e.g. like the one that is used inside the CV 2 connection box, see figure 5.2). The shield of the power supply cable is connected to the base plate inside the CV 2.

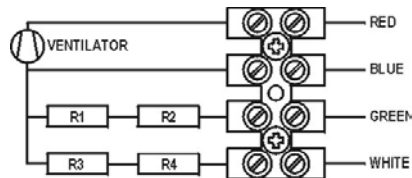

Figure 5.2 Connection block inside the CV 2

The DC output from the power supply unit is marked with a red sleeve on the + wire.

For activating the ventilator the blue wire has to be connected to the 0 Volt, the red wire has to be connected to the + 12 Volt.

The heater also uses the common blue wire as 0 Volt and green/white as the + 12 Volt connection

When only the green or white is connected the heating power is 5 Watt.

When both green and white are connected the heating power is 10 Watt.

Because all resistors (R1 - R4) are mounted on a metal ring around the ventilation shaft, the dissipated heat is equally spread over the opening. Therefore it does not matter whether the green or white wire is used for 5-Watt operation.

The need for heating strongly differs on local climatological circumstances. Generally heating is advised during cold seasons when frost and dew can be expected.

6. MAINTENANCE AND OPERATING

The ISO TR 9901 recommendations for maintenance and operation of pyranometers must be observed.

The ventilator is meant to run continuously.

The operational state of the ventilator, of the heating elements, and of the air ducts, must be checked regularly (see figure 6.1).

The air filter is located on the bottom of the CV 2. The filter can be checked and changed by removing the cover from the filter by pulling it down with two hands on both sides of the CV 2.

The filter has to be free of dust particles and holes. New air filters can be ordered at Kipp & Zonen (see chapter 8).

After cleaning or renewal the filter can be placed in the filter cover. The letter can be pressed upward on the ventilator.

The filter cover clicks on the ventilator.

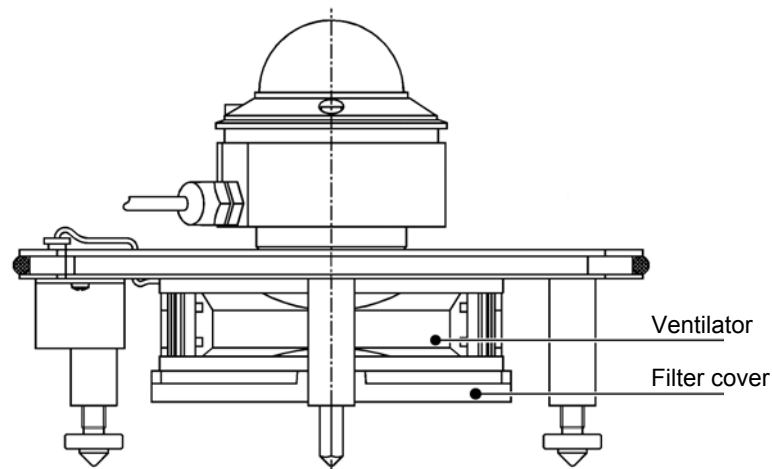

Figure 6.1 Ventilator and filter unit

7. TROUBLE SHOOTING

Malfunction	Cause	Check
Ventilator and heater don't work	Power failure	Check 12 VDC or check mains voltage
Ventilator does not work	Electrical connections	Check impedance R1 to R4 = 4 x 15 Ω
	Power supply	Check voltage
	Obstruction	Check interior

See figure 5.2 and 6.1 for locations to check.

8. PART NUMBERS / SPARE PARTS / OPTIONS

CV 2	0349 900
CV 2 with heater	0349 901
Cap (cover)	0015 601
Rubber ring	2132 170
Spare air filters (set of 5)	2682 916
Power supply for CV 2 with heater	0349 401

The ventilator and heating elements are specially prepared for outdoor use.
Please ask Kipp & Zonen in case of repair or replacement.

CUSTOMER SUPPORT

Our customer support remains at your disposal for any maintenance or repair, calibration, supplies and spares. The address is as follows:

Für Servicearbeiten und Kalibrierung, Verbrauchsmaterial und Ersatzteile steht Ihnen unsere Customer Support Abteilung unter folgender Adresse zur Verfügung:

Notre service 'Support Clientèle' reste à votre entière disposition pour tout problème de maintenance, réparation ou d'étalonnage ainsi que pour les accessoires et pièces de rechange. Leur adresse est la suivante :

Holland **Kipp & Zonen B.V.**
Röntgenweg 1
2624 BD DELFT
T +31 15 269 8000
F +31 15 262 0351
E kipp.holland@kippzonen.com

USA **Kipp & Zonen USA Inc.**
125, Wilbur Place
BOHEMIA/NY 11716
T +1 631 589 2065
F +1 631 589 2068
E kipp.usa@kippzonen.com

UK **Kipp & Zonen Ltd.**
P.O. Box 819,
LINCOLN, Lincolnshire LN6 0WY
T +44 1522 695 403
F +44 1522 696 598
E kipp.uk@kippzonen.com

France **Kipp & Zonen S.A.R.L.**
7, avenue Clément Ader
ZA Ponroy - Bât. M
F-94420 LE PLESSIS TREVISE
T +33 1 49 62 4104
F +33 1 49 62 4102
E kipp.france@kippzonen.com

Germany **Gengenbach Messtechnik**
Heinrich-Otto-Strasse 3
D-73262 REICHENBACH/FILS
T +49 7153 9258 0
F +49 7153 9258 160
E info@rg-messtechnik.de



WWW.KIPPZONEN.COM