

Scripps Institution of Oceanography Shipboard Technical Support La Jolla CA 92093-0214		
Title RS232 SPLITTER V2.0		
Size B	Document Number 031400 CM	Rev A
Date: Wednesday, February 25, 2004	Sheet 1	of 2

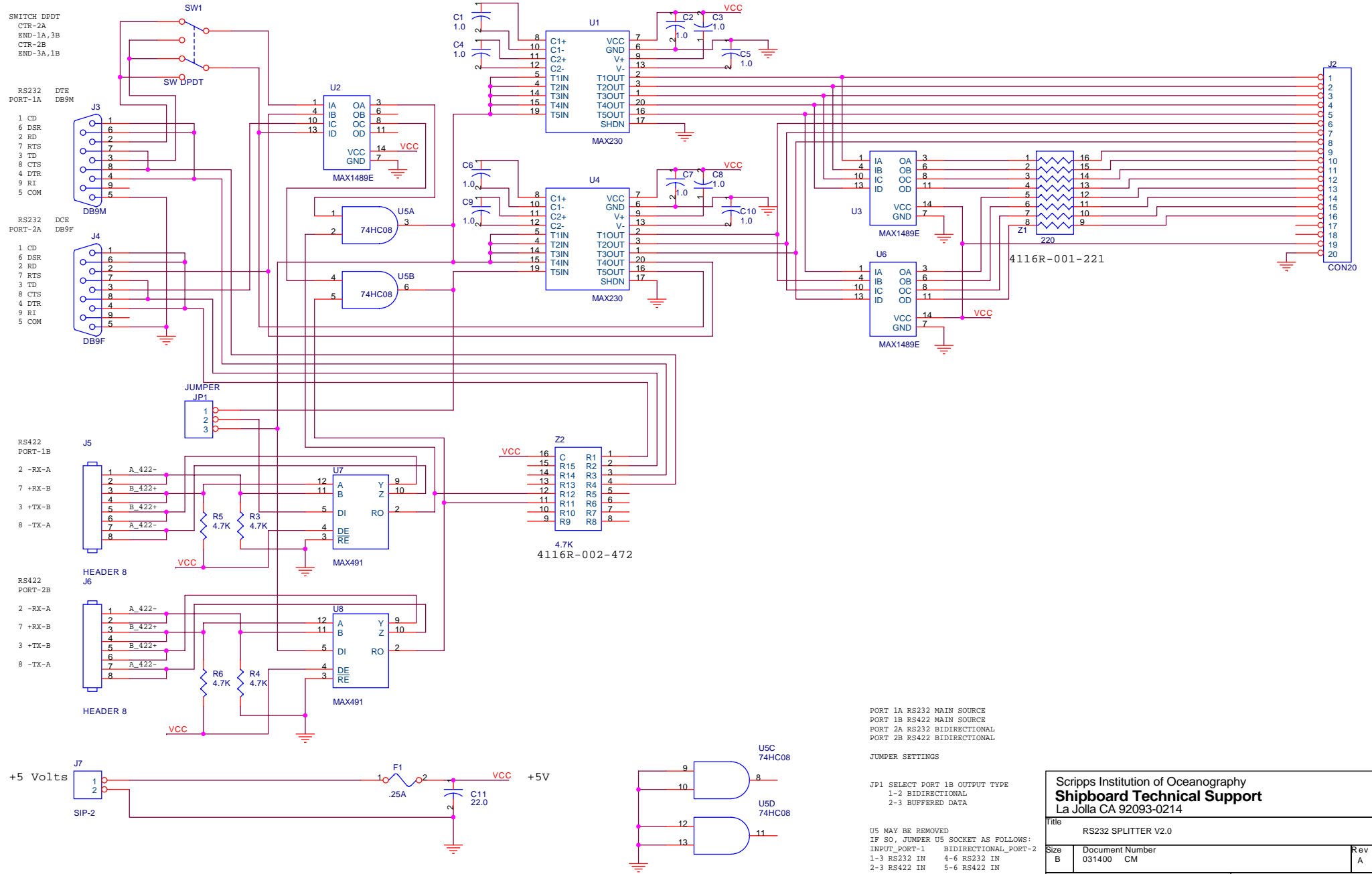

PORT 1A RS232 MAIN SOURCE
 PORT 1B RS422 MAIN SOURCE
 PORT 2A RS232 BIDIRECTIONAL
 PORT 2B RS422 BIDIRECTIONAL

JUMPER SETTINGS

JP1 SELECT PORT 1B OUTPUT TYPE
 1-2 BIDIRECTIONAL
 2-3 BUFFERED DATA

U5 MAY BE REMOVED
 IF SO, JUMPER U5 SOCKET AS FOLLOWS:
 INPUT_PORT-1 BIDIRECTIONAL_PORT-2
 1-3 RS232 IN 4-6 RS232 IN
 2-3 RS422 IN 5-6 RS422 IN

Scripps Institution of Oceanography Shipboard Technical Support La Jolla CA 92093-0214		
Title		
RS232 SPLITTER V2.0		
Size	Document Number	Rev
B	031400 CM	A
Date:	Wednesday, February 25, 2004	Sheet 2 of 2