

Operating Manual

Spectra 2420
2.4GHz Spread Spectrum Wireless Modem
Firmware Version 3.1092A
Document: Spectra 2420.OM.F31092A.Rev2.0

October 01, 2007



17-2135-32 Avenue NE
Calgary, Alberta
Canada T2E 6Z3
Phone: (403) 248-0028
Fax: (403) 248-2762
www.microhardcorp.com

Important User Information

Warranty

Microhard Systems Inc. warrants that each product will be free of defects in material and workmanship for a period of one (1) year for its products. The warranty commences on the date the product is shipped by Microhard Systems Inc. Microhard Systems Inc.'s sole liability and responsibility under this warranty is to repair or replace any product which is returned to it by the Buyer and which Microhard Systems Inc. determines does not conform to the warranty. Product returned to Microhard Systems Inc. for warranty service will be shipped to Microhard Systems Inc. at Buyer's expense and will be returned to Buyer at Microhard Systems Inc.'s expense. In no event shall Microhard Systems Inc. be responsible under this warranty for any defect which is caused by negligence, misuse or mistreatment of a product or for any unit which has been altered or modified in any way. The warranty of replacement shall terminate with the warranty of the product.

Warranty Disclaims

Microhard Systems Inc. makes no warranties of any nature of kind, expressed or implied, with respect to the hardware, software, and/or products and hereby disclaims any and all such warranties, including but not limited to warranty of non-infringement, implied warranties of merchantability for a particular purpose, any interruption or loss of the hardware, software, and/or product, any delay in providing the hardware, software, and/or product or correcting any defect in the hardware, software, and/or product, or any other warranty. The Purchaser represents and warrants that Microhard Systems Inc. has not made any such warranties to the Purchaser or its agents MICROHARD SYSTEMS INC. EXPRESS WARRANTY TO BUYER CONSTITUTES MICROHARD SYSTEMS INC. SOLE LIABILITY AND THE BUYER'S SOLE REMEDIES. EXCEPT AS THUS PROVIDED, MICROHARD SYSTEMS INC. DISCLAIMS ALL WARRANTIES, EXPRESS OR IMPLIED, INCLUDING ANY WARRANTY OF MERCHANTABILITY OR FITNESS FOR A PARTICULAR PROMISE.

MICROHARD SYSTEMS INC. PRODUCTS ARE NOT DESIGNED OR INTENDED TO BE USED IN ANY LIFE SUPPORT RELATED DEVICE OR SYSTEM RELATED FUNCTIONS NOR AS PART OF ANY OTHER CRITICAL SYSTEM AND ARE GRANTED NO FUNCTIONAL WARRANTY.

Indemnification

The Purchaser shall indemnify Microhard Systems Inc. and its respective directors, officers, employees, successors and assigns including any subsidiaries, related corporations, or affiliates, shall be released and discharged from any and all manner of action, causes of action, liability, losses, damages, suits, dues, sums of money, expenses (including legal fees), general damages, special damages, including without limitation, claims for personal injuries, death or property damage related to the products sold hereunder, costs and demands of every and any kind and nature whatsoever at law.

IN NO EVENT WILL MICROHARD SYSTEMS INC. BE LIABLE FOR ANY INDIRECT, SPECIAL, CONSEQUENTIAL, INCIDENTAL, BUSINESS INTERRUPTION, CATASTROPHIC, PUNITIVE OR OTHER DAMAGES WHICH MAY BE CLAIMED TO ARISE IN CONNECTION WITH THE HARDWARE, REGARDLESS OF THE LEGAL THEORY BEHIND SUCH CLAIMS, WHETHER IN TORT, CONTRACT OR UNDER ANY APPLICABLE STATUTORY OR REGULATORY LAWS, RULES, REGULATIONS, EXECUTIVE OR ADMINISTRATIVE ORDERS OR DECLARATIONS OR OTHERWISE, EVEN IF MICROHARD SYSTEMS INC. HAS BEEN ADVISED OR OTHERWISE HAS KNOWLEDGE OF THE POSSIBILITY OF SUCH DAMAGES AND TAKES NO ACTION TO PREVENT OR MINIMIZE SUCH DAMAGES. IN THE EVENT THAT REGARDLESS OF THE WARRANTY DISCLAIMERS AND HOLD HARMLESS PROVISIONS INCLUDED ABOVE MICROHARD SYSTEMS INC. IS SOMEHOW HELD LIABLE OR RESPONSIBLE FOR ANY DAMAGE OR INJURY, MICROHARD SYSTEMS INC.'S LIABILITY FOR ANY DAMAGES SHALL NOT EXCEED THE PROFIT REALIZED BY MICROHARD SYSTEMS INC. ON THE SALE OR PROVISION OF THE HARDWARE TO THE CUSTOMER.

Proprietary Rights

The Buyer hereby acknowledges that Microhard Systems Inc. has a proprietary interest and intellectual property rights in the Hardware, Software and/or Products. The Purchaser shall not (i) remove any copyright, trade secret, trademark or other evidence of Microhard Systems Inc.'s ownership or proprietary interest or confidentiality other proprietary notices contained on, or in, the Hardware, Software or Products, (ii) reproduce or modify any Hardware, Software or Products or make any copies thereof, (iii) reverse assemble, reverse engineer or decompile any Software or copy thereof in whole or in part, (iv) sell, transfer or otherwise make available to others the Hardware, Software, or Products or documentation thereof or any copy thereof, except in accordance with this Agreement.

Important User Information (continued)

About This Manual

It is assumed that users of the products described herein have either system integration or design experience, as well as an understanding of the fundamentals of radio communications.

Throughout this manual you will encounter not only illustrations (that further elaborate on the accompanying text), but also several symbols which you should be attentive to:



Caution or Warning

Usually advises against some action which could result in undesired or detrimental consequences.



Point to Remember

Highlights a key feature, point, or step which is noteworthy. Keeping these in mind will simply or enhance device usage.



Tip

An idea or suggestion to improve efficiency or enhance usefulness.

Important User Information (continued)

Spectra 2420 Regulatory Requirements

PLEASE READ THIS SECTION CAREFULLY



WARNING:

To satisfy FCC RF exposure requirements for mobile transmitting devices, a separation distance of 23 cm or more should be maintained between the antenna of this device and persons during device operation. To ensure compliance, operations at closer than this distance is not recommended. The antenna used for this transmitter must not be co-located in conjunction with any other antenna or transmitter.



WARNING:

Changes or modifications not expressly approved by Microhard Systems Inc. could void the user's authority to operate the equipment. This device has been tested with MCX and Reverse Polarity SMA connectors with the antennas listed in Appendix A. When integrated in OEM products, fixed antennas require installation preventing end-users from replacing them with non-approved antennas. Antennas not listed in the tables must be tested to comply with FCC Section 15.203 (unique antenna connectors) and Section 15.247 (emissions).



WARNING:

MAXIMUM EIRP

FCC Regulations allow up to 36 dBm equivalent isotropically radiated power (EIRP). Therefore, the sum of the transmitted power (in dBm), the cabling loss and the antenna gain cannot exceed 36 dBm.



WARNING:

EQUIPMENT LABELING

The FCC and IC numbers depend on the model of the radio module. Do NOT use the Marketing Name of the product but the Model to distinguish the Certifications Numbers. This device has been modularly approved. The manufacturer, product name, and FCC and Industry Canada identifiers of this product must appear on the outside label of the end-user equipment.

SAMPLE LABEL REQUIREMENT:

FCCID: NS907P22
IC: 3143A-07P22

This device complies with Part 15 of the FCC Rules. Operation is subject to the following two conditions: (1) this device may not cause harmful interference, and (2) this device must accept any interference received including interference that may cause undesired operation.

Revision History

Revision 2.0

October 01, 2007

Table of Contents

1.0 Overview	9
1.1 Performance Features	9
1.2 Specifications	11
2.0 QUICK START	13
2.1 Required Materials	13
2.2 Set-Up Procedure	13
3.0 Hardware Features	14
3.1 Connections	14
3.1.1 Front	14
3.1.2 Rear	16
3.2 Indicators	18
4.0 Operating Modes	20
4.1 Command Mode	20
4.1.1 How to Enter Command Mode	20
4.2 Data mode	21
4.3 Master	21
4.4 Repeater	21
4.5 Slave	21
5.0 Network Topologies	22
5.1 Point-to-Point (PTP)	22
5.2 Point-to-Multipoint (PMP)	25
5.2.1 Point-to-Multipoint TDMA	27
5.3 Peer-to-Peer (P2P)	29
5.4 Everyone-to-Everyone (E2E)	30
6.0 Configuration	31
6.1 AT Commands	32
A Answer	32
D/DT/DPxxxxx Dial	32
g, G Spectrum Analyzer	33
In Identification	34
N Advanced Spectrum Analyzer	35
O Online Mode	35
&Fn Load Factory Default Configuration	35

Table of Contents (continued)

6.0 Configuration (continued)

6.1 AT Commands (continued)	
&H0 Frequency Restriction	37
&H1 Repeater Registration	39
&V View Configuration	39
&W Write Configuration to Memory	39
6.2 Settings (S) Registers	40
S0 Auto Answer	40
S1 Escape Code	40
S101 Operating Mode	41
S102 Serial Baud Rate	42
S103 Wireless Link Rate	42
S104 Network Address	43
S105 Unit Address	43
S107 Static Mask	44
S108 Output Power	45
S109 Hop Interval	46
S110 Data Format	47
S112 Packet Max Size	47
S113 Packet Retransmissions	48
S115 Repeat Interval	49
S116 Character Timeout	50
S118 Roaming	51
S119 Quick Enter to Command Mode	52
S123 Average RSSI	53
S133 Network Type	53
S140 Destination Address	54
S141 Repeaters Y/N	54
S142 Serial Channel Mode	55
S143 Sleep Mode	56
S144 Sleep Time	58
S145 Wake Time	59
S149 LED Brightness	59
S150 Sync Mode	60
S151 Fast Sync Timeout	60
S153 Address Tag	61
S158 Forward Error Correction (FEC) Mode	62
S217 Protocol Type	63
S237 Sniff Timeout	64
S244 Channel Request Mode	65
S251 Master Hop Allocation Timeout	66

Table of Contents

6.0 Configuration (continued)	
6.3 Serial Interface Commands	67
&Cn Data Carrier Detect (DCD)	68
&Dn Data Terminal Ready (DTR)	69
&K Handshaking	69
&Sn Data Set Ready (DSR)	70
7.0 Installation	71
7.1 Path Calculation	74
7.2 Installation of Antenna System Components	75
7.2.1 Antennas	76
7.2.2 Coaxial Cable	77
7.2.3 Surge Arrestors	78
Appendices	
Appendix A: Approved Antennas	79
Appendix B: AT Command Quick Reference	80
Appendix C: Settings (S) Register Quick Reference	82
Appendix E: Mounting Dimensions	84
Appendix F: Serial Interface	85
Appendix G: RS-485 Wiring	86

1.0 Overview

The Spectra 2420 delivers high-performance wireless serial communications in a variety of network topologies.

When properly configured and installed, long range communications at very high speeds can be achieved.

Spectra 2420 modems operate within the 2.400 to 2.4835GHz ISM frequency band, using frequency hopping spread spectrum (FHSS) technology. They provide reliable wireless asynchronous data transfer between most equipment types which employ an RS232, RS422, or RS485 interface.

The small size and superior performance of the Spectra 2420 makes it ideal for many applications. Some typical uses for this modem:

- SCADA
- remote telemetry
- traffic control
- industrial controls
- remote monitoring
- fleet management
- GPS
- wireless video
- robotics
- display signs
- railway signaling

1.1 Performance Features

Key performance features of the Spectra 2420 include:

- transmission within a public, license-exempt band of the radio spectrum¹ - this means that the modems may be used without access fees or recurring charges (such as those incurred by cellular airtime)
- transparent, low latency link providing up to 230kbps continuous throughput
- communicates with virtually all PLCs, RTUs, and serial devices through either an RS232, RS422, or RS485 interface
- industrial temperature specifications
- supports point-to-point, point-to-multipoint, peer-to-peer, store and forward repeater
- maximum allowable transmit power (1 Watt)

1.0 Overview

- low power consumption in Sleep Mode (real-time clock wakeup)
- 32 bits of CRC, selectable retransmission and forward error correction
- separate diagnostics port - transparent remote diagnostics and online network control
- ease of installation and use - the Spectra 2420 utilizes a subset of standard AT-style commands, similar to those used by traditional telephone line modems

While the typical application of Spectra 2420 modems is to provide short- to mid-range wireless communications between DTEs, they can be adapted to almost any situation where an asynchronous serial interface is used and data intercommunications is required.

1 2.400-2.4835GHz, which is license-exempt within North America, may need to be factory-configured differently for other areas: contact Microhard Systems Inc.

1.0 Overview

1.2 Specifications

Refer to the Specifications Sheet supplied to you for your particular model.

1.0 Overview

This page intentionally left blank.

2.0 Quick Start

This QUICK START guide will enable you to promptly establish basic connectivity between a pair of Spectra 2420 modems in a point-to-point (ref. 5.1) configuration.

2.1 Required Materials

- 2 Spectra 2420 modems, each with Power Adapter and Rubber Ducky Antenna
- 2 PCs with HyperTerminal (or equivalent) and 1 COM port each, or
1 PC with HyperTerminal and 2 COM ports
- 2 straight-through serial cables (9-pin M to 9-pin F)

2.2 Set-Up Procedure

- Connect straight-through cable from each modem (rear 'RS-232' port) to COM port of PC (see 3.1.2).
- Open a HyperTerminal session for each modem connection, and configure it as 9600, 8 data bits, no parity, 1 stop bit, and no handshaking - then open the 'connection' (at bottom left of HyperTerminal window, the word 'Connected' should appear).
- Plug power adapter into wall outlet and, while depressing the CFG button on the modem, attach the 'green' connector of the wall adapter cable to the rear of the Spectra 2420; repeat with other modem (see 3.1.1, 3.1.2).
- When Step 3 is performed, the HyperTerminal window should show the response 'NO CARRIER OK'.
- At this point, both modems are in COMMAND MODE. On one modem (to be the MASTER), type AT&F6 [Enter], then type AT&WA [Enter]. This modem's TX LED (red) should now be illuminated. For the other modem (to be the SLAVE), type AT&F7 [Enter], then type AT&WA [Enter]. This modem's RX and 3 RSSI LED's should illuminate.
- We now have 'radio' connectivity. If text is entered in one PC's HyperTerminal window, it should appear in the other's; and vice versa.

3.0 Hardware Features

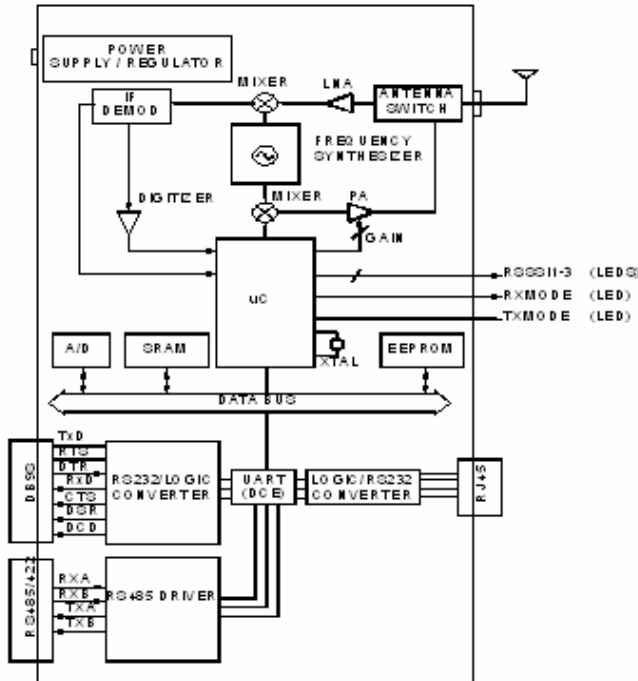

The Spectra 2420 is a fully-enclosed unit ready to be interfaced to external devices.

Any Spectra 2420 modem may be configured as a Master, Repeater (or Repeater/Slave), or Slave. This versatility is very convenient from a 'sparing' perspective, as well for convenience in becoming very familiar and proficient with using the modem: if you are familiar with one unit, you will be familiar with all units.

Drawing 1: Functional Block Diagram

3.1 Connections

3.1.1 Front

On the front of the Spectra 2420 is the SERIAL DIAGNOSTICS port. The connector is an RJ45; signal levels are RS232. Also, note the small CFG (configuration) pushbutton.



Image 1: Front View of Spectra 2420

3.0 Hardware Features

CFG Button

Holding this button depressed while powering-up the modem will boot the unit into configuration mode: the default serial interface (rear DE9, RS232) will be active and set to operate at its default serial baud rate of 9600bps.



The SERIAL DIAG port is NOT an Ethernet port.

The SERIAL DIAG port does not support AT commands.

The **SERIAL DIAG** port is used for two purposes:

- online diagnostics and configuration at 115.2kbps (using MHS-supplied BLACK RJ45-DE9 cable (P/N MHS044000) and MHS software)
- firmware upgrade (using MHS-supplied BLUE RJ45-DE9 cable (P/N MHS044010))

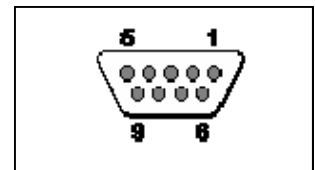
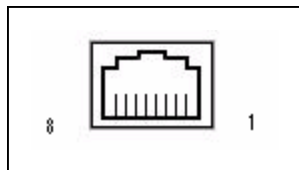

RJ45 Pin No.	Name	MHS044000 DE9 Pin No.	MHS0044010 DE9 Pin No.
1			4
2	Diag RXD	2	
3	Diag TXD	3	
4			3
5	SG	5	5
6			2
7	RESET*		
8			7

Table 1: SERIAL DIAG Port Cable Pin-Outs

3.0 Hardware Features

3.1.2 Rear

RS232 Port (DCE) on the rear of the Spectra 2420 is used for

- RS232 serial data (300-230,400bps) when in DATA MODE, or
- for configuring the modem when in COMMAND MODE.

RS422/485 Port used to interface the Spectra 2420 to a DTE with the same interface type.

Either the RS232 or RS422/485 interface is used for data traffic.



Image 2: Rear View of Spectra 2420

DE9S Pin No.	Name	Input or Output
1	DCD	O
2	RXD	O
3	TXD	I
4	DTR	I
5	SG	
6	DSR	O
7	RTS	I
8	CTS	O
9	Not Used	

Table 2: RS232 Pin Assignment

3.0 Hardware Features



Caution: Using a power supply that does not provide proper voltage and current may damage the modem.

Green Connector Pin No.	Name	Input or Output
1	TxB (D+)	O
2	TxA (D-)	O
3	RxB (R+)	I
4	RxA (R-)	I
5	Not Used	
6	SHDN	I
7	Vin -	
8	Vin +	I

Table 3: Phoenix-type Connector Pin Assignment

Grounding the SHDN pin shuts down the modem.

Antenna Connector

The Spectra 2420 uses a reverse polarity TNC (RP-TNC) connector. Microhard Systems Inc. can provide external cabling and antennas suited to a variety of applications where the standard rubber ducky antenna is not adequate.

3.0 Hardware Features

3.2 Indicators

Referring to Section 3.1.1 Image 1 and Table 4, it can be seen that a number of indicators are available which conveniently show the status of the modem's RF and serial data communications.

- **System Status LED (Green)**

Location: top right of the front panel RJ45 jack.

This LED is illuminated when the system is powered-up and core status is okay. This is the only LED that is illuminated when the modem is in COMMAND MODE.

- **RX/SYNC LED (Green)**

When lit, this LED indicates that the modem is synchronized and has received valid packets.

- **TX LED (Red)**

When illuminated, this LED is indicating that the modem is transmitting data over the air.

- **Receive Signal Strength Indicator (RSSI) (3x Green)**

As the received signal strength increases, starting with the furthest left, the number of active RSSI LEDs increases.

Signal strength is calculated based on the last four valid received packets with correct CRC.

RSSI is also reported in S123.

3.0 Hardware Features

MODE	M/R/S	RX/SYNC	LED STATUS	
			TX	RSSI 1,2,3
COMMAND	All	OFF	OFF	OFF
DATA	Master	ON while receiving valid data packets from Slaves and Repeaters in the network	ON	1-3 ON in proportion to signal strength received from Slaves and Repeaters in the network
Fast Sync	Master	OFF	ON	Cycling with 300ms ON time
DATA - during sync. acquisition	Repeater	OFF	OFF	Cycling with 300ms ON time
DATA - when synchronized	Repeater	ON for first portion of hop interval	ON for second portion of hop interval	1-2 ON in proportion to signal strength received from Slaves; if Slaves silent for >2s, Repeater will indicate RSSI based on signal strength received from Master
DATA - during sync. acquisition	Slave	OFF	OFF	Cycling with 300ms ON time
DATA - when synchronized	Slave	ON	ON when transmitting a packet	1-3 ON in proportion to signal strength received from Repeater or Master with which Slave communicates

Table 4: LED Operation

4.0 Operating Modes

4.1 Command Mode

In this mode:

- the modem is offline (data is not passing through the modem via it's local data port or RF communications)
- the only LED illuminated will be the small green LED at the top right of the front panel SERIAL DIAG (RJ45) port
- the modem's configuration options (registers) may be viewed and modified

4.1.1 How to Enter Command Mode

Two methods are typically used to place the Spectra 2420 into command mode:

1. Force to Command Mode

- power off the modem
- connect a 9-pin straight-through serial cable from PC COM port to the Spectra 2420's rear RS-232 port
- launch a terminal communications program (e.g. HyperTerminal) and configure for 9600bps, 8 data bits, No parity, 1 stop bit (8N1)
- press and hold the Spectra 2420's CFG button (on front of unit)
- continue to press the CFG button and apply power to the modem
- release the CFG button
- observe the front panel of the modem: only the small green LED should be illuminated, indicating that the modem is in Command Mode.

2. Escape from Data Mode

- with modem 'online', connect a 9-pin straight-through serial cable from PC COM port to the Spectra 2420's rear RS-232 port
- launch a terminal communications program (e.g. HyperTerminal) and configure for the modem's established serial baud rate parameters (PC & modem must match)
- pause 1 second, type '+++ ' (see Section 6.2, S1), pause 1 second: the monitor should show the modem response of 'NO CARRIER OK'
- the modem is now in Command Mode (observe front panel: only the small green LED should be illuminated)

4.0 Operating Modes

4.2 Data Mode

The normal operational state of all deployed Spectra 2420 modems. In this mode the modem is prepared to exchange data as per its configuration settings. Front panel LEDs provide an indication of the data exchange (TX and RX LEDs).

To enter DATA mode from COMMAND mode, enter the command: *ATA [Enter]* .

The following three modes are the 'radio network' roles (see Section 6.2, S101):

4.3 Master

One per network, the source of synchronization for the system. The Master controls the flow of data through the system; all data passes to or through it.

4.4 Repeater

Required only if necessary to establish a radio path between a Master and Slave(s); stores and forwards the data sent to it. Synchronizes to Master and provides synchronization to 'downstream' units.

If a local device is attached to a Repeater's serial data port, the Repeater will also behave as a Slave (aka Repeater/Slave).

Adding one or more Repeaters within a network will HALVE the throughput; the throughput is halved only once, i.e. it does not decrease with the addition of more Repeaters.

If there is a 'path' requirement to provide Repeater functionality, but throughput is critical, this may be accomplished by placing two modems at the Repeater site in a 'back-to-back' configuration. One modem would be configured as a Slave in the 'upstream' network; the other a Master (or Slave) in the 'downstream' network. Local connection between the modems would be accomplished with a 'null modem' cable. Each modem would require its own antenna; careful consideration should be given with respect to antenna placement and modem configuration.

4.5 Slave

Endpoint/node within a network to which a local device is attached. Communicates with Master either directly or through one or more Repeaters. See Sections 5.3 and 5.4 for information regarding 'Slave-to-Slave' communications.

5.0 Network Topologies

The Spectra 2420 may be configured to operate in a number of different operating modes and participate in various network topologies.

Note: This section describes network topologies and also contains details regarding related factory default settings to enable the reader to readily see the correlation between various registers. Refer to section 6 for further detailed information regarding configuration options and details.

For convenience, a number of factory default configurations related both to operating modes and network topologies are available. Configuring modems using factory default settings has the following benefits:

- hastens the configuration process
load default and, if necessary, apply only minor settings adjustments
- aids in troubleshooting
if settings have been adjusted and basic communications cannot be established, simply revert to the applicable factory default setting and any improper adjustments will be overwritten and a 'fresh start' can be made - with known-to-work settings

Settings (S) register S133 configures the modem for the 'Network Type' within which it will be participating.

5.1 Point-to-Point (PTP)

In a point-to-point network, a path is created to transfer data between Point A and Point B, where Point A may be considered the Master modem and Point B a Slave. Such a PTP network may also involve one or more Repeaters (in a store-and-forward capacity) should the radio signal path dictate such a requirement.

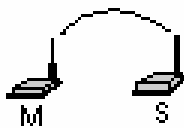

A PTP configuration may also be used in a more dynamic sense: there may be many Slaves (and Repeaters) within such a network, however the Master may have its 'Destination Address' (S140) changed as and when required to communicate with a specific Slave.

PTP factory default settings:	Master	&F6
	Slave	&F7
slow mode (optional) :	Master	&F8
	Slave	&F9

5.0 Network Topologies

The screen captures on this page clearly show that most of the registers in both the Master and the Slave have the same values.

(S105 is not visible in the Master view: its value is, and must be, 1.)

The differences are S101 (Operating Mode), S105 (Unit Address), and S140 (Destination Address).

The nature of PTP is clear: The Master's destination (S140) is 2 (the Unit Address (S105) of the Slave); the Slave's destination is the

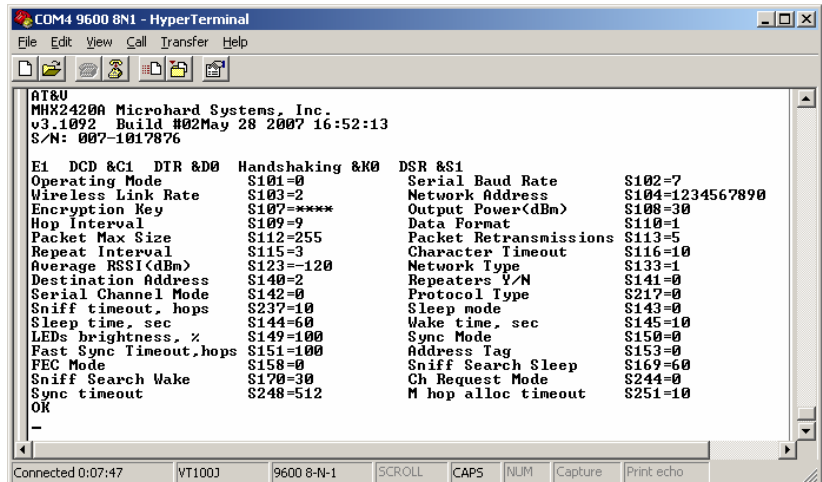

Image 3: &F6 PTP Master Configuration View

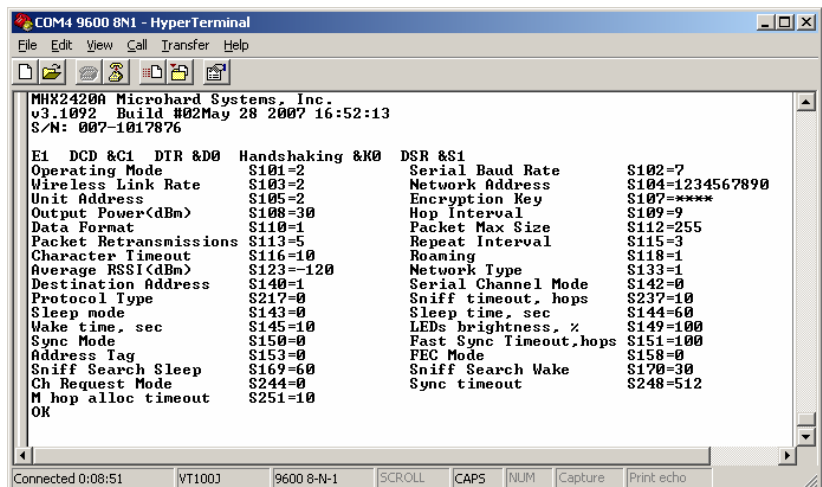

Image 4: &F7 PTP Slave Configuration View

5.0 Network Topologies

'Network Type' (S133) is set to 1 for PTP operation.

Note that the Master has a register 'S141 - Repeaters Y/N' and the Slave does not. This register informs the Master of there being one or more Repeaters in this network. The factory defaults assume 'no' and assign a value of 0. If a Repeater is to be installed, and all the Master and Slave defaults will be maintained, following is a procedure on how to configure a Repeater into this fixed (non-mobile) PTP network:



Master

- enter into Command Mode
- change S141 (Repeaters Y/N) to 1 (which means 'Yes')
- save the change using the AT&W command
- go online with the ATA command

Repeater

- enter into Command Mode
- load a third modem with &F7 (PTP Slave factory default settings)
- change the Operating Mode (S101) from 2 (Slave) to 1 (Repeater)
- change the Unit Address (UA) (S105) from 2 to 3
- save the changes using the AT&W command
- go online with the ATA command

Slave

- enter into Command Mode
- change S118 from 1 (the UA of the Master) to 3 (the UA of the Repeater)
- save the change using the AT&W command
- go online with the ATA command

This system may be tested by sending text at 9600bps, 8N1 through the RS-232 serial port of one modem and observing that it appears at the RS-232 serial port of the other modem. The Slave is synchronized to the Repeater, which in turn is synchronized to the Master. If the Repeater is taken offline, in a matter of moments the Slave's RSSI LEDs will indicate that it is 'scanning' for its immediate upstream unit; place the Repeater online and the Slave will quickly acquire it. If the Master is taken offline, both the Repeater and Slave will begin to scan.

5.0 Network Topologies

5.2 Point-to-Multipoint (PMP)

In a point-to-multipoint network, a path is created to transfer data between the Master modem and numerous remote modems. The remote modems may simply be Slaves with which the Master communicates directly, and/or Slaves which communicate via Repeaters. Some or all of the Repeaters may also act as Slaves in this type of Network, i.e. the Repeaters are not only storing and forwarding data, but are also acting as Slaves. Such Repeaters may be referred to as 'Repeater/Slaves'.

PMP factory default settings: **Master** &F1
 Slave &F2
 Repeater &F3

slow mode (optional) : Master &F4
 Slave &F5

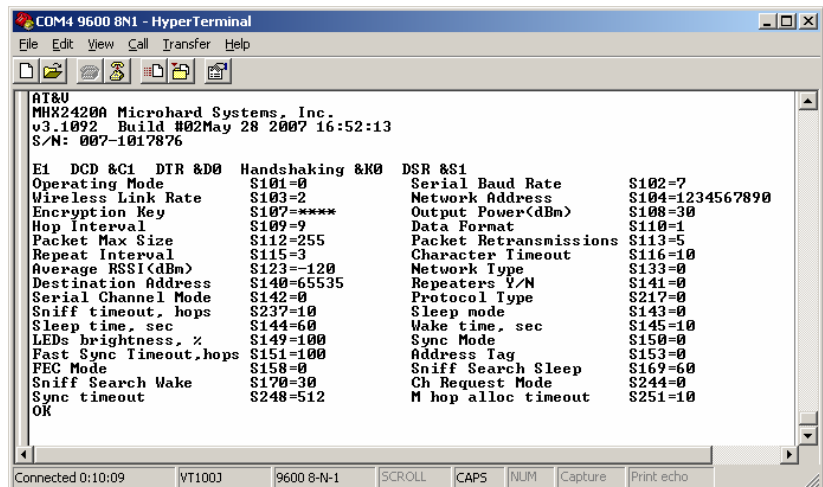
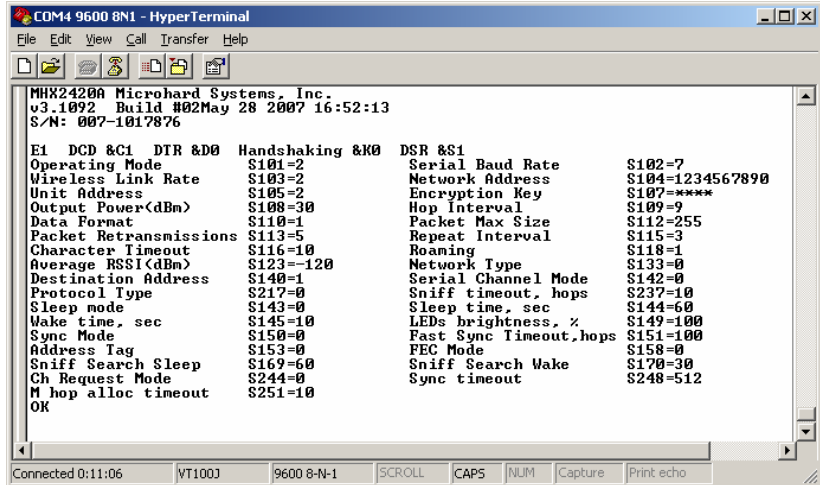

Image 5: &F1 PMP Master Configuration View

The factory default PMP Master configuration reveals the following differences with respect to the PTP factory default Master: S133=0 (PMP network) and S140=65535 (the broadcast address, indicating that this Master (*point*) will send its data to all modems - *multipoint*). On a **PMP Master**, set **S113=0** and increase only if required.

5.0 Network Topologies



```

COM4 9600 8N1 - HyperTerminal
File Edit View Call Transfer Help

MHX2420A Microhard Systems, Inc.
v3.1092 Build #02May 28 2007 16:52:13
S/N: 007-1017876

E1 DCD &C1 DTR &D0 Handshaking &K0 DSR &S1
Operating Mode S101=2 Serial Baud Rate S102=7
Wireless Link Rate S103=2 Network Address S104=1234567890
Unit Address S105=2 Encryption Key S107=****
Output Power(dBm) S108=30 Hop Interval S109=9
Data Format S110=1 Packet Max Size S112=255
Packet Retransmissions S113=5 Repeat Interval S115=3
Character Timeout S116=10 Roaming S118=1
Average RSSI(dBm) S123=-120 Network Type S133=0
Destination Address S140=1 Serial Channel Mode S142=0
Protocol Type S217=0 Sniff timeout, hops S237=10
Sleep mode S143=0 Sleep time, sec S144=60
Wake time, sec S145=10 LEDs brightness, % S149=100
Sync Mode S150=0 Fast Sync Timeout,hops S151=100
Address Tag S153=0 FEC Mode S158=0
Sniff Search Sleep S169=60 Sniff Search Wake S170=30
Ch Request Mode S244=0 Sync timeout S248=512
M hop alloc timeout S251=10
OK
    
```

Image 6: &F2 PMP Slave Configuration View



Each modem in any network must have a unique Unit Address.

Insofar as the factory defaults are concerned, the difference between the PMP Master and PMP Slave (above) are simply the Operating Mode (S101), Unit Address (S105), and the Destination Address (S140).



When bench testing PMP and using the factory default settings for the Master, Repeater, and Slave:

With the exception of the Master modem, all modems in a PMP network have a Destination Address of 1 - the UA of Master modem - to which all data is destined.

The settings for a factory default PMP Repeater are unique only with respect to S101 (1) and S105 (3).

Master S141 must be changed from 0 to 1, and Slave S118 must be modified to be the UA of the Repeater (3), otherwise the Slave will synchronize directly to the Master, bypassing the Repeater.

5.0 Network Topologies

5.2.1 Point-to-Multipoint TDMA

Time Division Multiple Access (TDMA) is available as a special form of the PMP network topology.

In TDMA mode, the Master modem will sequence through the Remotes in the network allowing each one, in turn, to transmit its data. The maximum number of Remotes which can communicate with a Master in this configuration is sixteen (16).

To configure a TDMA network, the default settings described in 5.2 are applicable, with the exception that the following registers (ref. Section 6.2) on the Master must be modified as required:

- S244 Channel Request Mode
- S251 Master Hop Allocation Timeout

For TDMA, set S244=1.

The default for S251 is 10 (hop intervals). If the system is to be deployed in a 'clean' RF environment, this number should perhaps be reduced to 2 or 3 to provide enough time for the Slave to initiate its response but to not potentially waste a significant number of hop intervals waiting for an unresponsive Slave to send data.

In addition, the following AT commands (ref. Section 6.1) are applicable to TDMA mode:

- T? view entire (maximum 16 item) Registered Slaves List
- Tn=UA enter a Slave's Unit Address (UA) into the Registered Slave's List item number n , where $n=0-15$, and $UA = 0-65534$ (selecting a UA value of 0 terminates the list)
- Tn? view Registered Slaves List entry number n , where $n=0-15$. Response is UA of List entry number.

The default Registered Slaves list consists of 16 entries (0-15), populated with Unit Addresses of 2 thru 17 respectively.

On the following page is an example to illustrate basic TDMA operation. For an actual deployment, application-specific parameters must be considered and other various modem configuration options optimized accordingly.

5.0 Network Topologies

Example:

5 Slaves, configured with PMP defaults (&F2). Unit Addresses: 3, 7, 10, 15, and 21. UA 3 has some data, 7 has no data, 10 has data, 15 is powered-off, and 21 has data but its RF connection is very intermittent due to an intermittent outdoor antenna connection. Master has been configured as PMP default Master (&F1). Clean RF environment.

Changes to be made to the Master:

S244=1
S251=3
ATT0=3
ATT1=7
ATT2=10
ATT3=15
ATT4=21
ATT5=0 (this terminates the list)

The Master will 'poll' (give the opportunity to transmit) the Slave with UA 3. This Slave will transmit all of its data and then inform the Master of same.

On the next hop, the Master will sequence to the next modem, UA 7. Slave 7 will inform the Master it has no data and on the next hop, the Master will sequence to UA 10.

Slave 10 will transmit its data and inform the Master when complete.

The Master then polls unit 15, no response. On the next hop interval, the Master will poll unit 15 again: no response. It will poll one more time on the following hop interval and, with no response, will move on to poll UA 21 which has data and sends it to the Master—but due to the faulty outdoor antenna connection, the Master does not receive the message from the Slave indicating that it has sent all of its data, so the Master will wait for the value of S251 (3 hops) for such a message from the Slave before moving on to begin the cycle again at UA 3.

5.0 Network Topologies

5.3 Peer-to-Peer (P2P)

P2P mode is used for communications between pairings of Remote modems,

e.g. Slave 12 can exchange data with (only) Slave 14, Slave 6 can exchange data with (only) Slave 7, etc.

There are no specific factory default settings for P2P modems.

To establish a basic P2P network:

Master

- enter into Command Mode
- load the &F1 factory default settings
- change the Network Type (S133) to 2
- change Packet Retransmissions (S113) from 5 to 0 (increase from 0 if required)
- save the change using the AT&W command
- go online with the ATA command

Slave 1

- enter into Command Mode
- load the &F2 factory default settings
- change the Network Type (S133) to 2
- change the Destination Address to 3 (to be the UA of Slave 2)
- save the change using the AT&W command
- go online with the ATA command

Slave 2

- enter into Command Mode
- load the &F2 factory default settings
- change the Network Type (S133) to 2
- change the Unit Address (S105) to 3
- change the Destination Address to 2 (the UA of Slave 1)
- save the change using the AT&W command
- go online with the ATA command

The Master will broadcast (actually 're-broadcast') the data incoming to it from both Slaves to all (2) Slaves; one Slave's data has a destination being the other Slave and vice versa.



A P2P network requires a Master modem.

The data being transmitted from one Slave to another in P2P mode is transferred via the Master.

5.0 Network Topologies

5.4 Everyone-to-Everyone (E2E)

E2E mode is used for communications between all remote modems, i.e. data from every modem is broadcast to every other modem in the network.



An E2E network requires a Master modem.

The data being transmitted from remote units in an E2E network travels to the Master and is then re-broadcast to all other remotes.

Considering the amount of data re-broadcasting (via the Master), it is a very bandwidth-intensive network topology.

There are no specific factory default settings to configure modems for E2E operation.

To establish a basic E2E network:

Master

- enter into Command Mode
- load the &F1 factory default settings
- change the Network Type (S133) to 2
- change Packet Retransmissions (S113) from 5 to 0 (increase from 0 if required)
- save the change using the AT&W command
- go online with the ATA command

Slaves

- enter into Command Mode
- load the &F2 factory default settings
- change the Network Type (S133) to 2
- change the Unit Address (S105) to a unique number (range: 2-65534)
- change the Destination Address to 65535 (the broadcast address)
- save the change using the AT&W command
- go online with the ATA command

6.0 Configuration

In following factors must be considered when preparing to configure the modems:

- the application
- network topology
- physical distribution of the network

Components involved in the configuration process of the Spectra 2420:

- Interfacing with the modem, and
- Inputting the desired values into a variety of registers

Interfacing to the Spectra 2420 modem for the purpose of configuring it may be accomplished in one of two ways:

- Rear RS-232 connector, 9-pin straight-through cable, and PC running communications program, or
- Front SERIAL DIAG RJ45 port, MHS configuration cable, and PC running MHS System Diagnostics software.

Once connected and in Command Mode, changes to the modem's configuration are made using convenient AT commands, the majority of which involve Settings (S) Registers.

As discussed in Section 5, there are several factory default settings which can make configuration of the modems quite simple. There are no DIP switches to set; switches which may subsequently become inadvertently misadjusted or intermittent.

6.0 Configuration

6.1 AT Commands

Appendix B is a quick reference for the available AT commands; in this sub-section are details regarding the most commonly used.

To invoke an AT command, enter Command Mode, then type **AT <command> [Enter]**.



If changes were made to the modem's configuration and it is intended that those changes be saved to non-volatile memory, do so with the AT command '&W' prior to placing the modem online.

```
y < command                command name > x
```

A **Answer**

Upon completion of tasks being done with the modem in Command Mode, invoking this command will place the modem back 'online' (into Data Mode).

Dxxxxx, DTxxxxx, DPxxxxx **Dial**

Identical commands which change the modem's unit address to xxxxx and then put the modem into Data Mode.

6.0 Configuration

g, G

Spectrum Analyzer

This is a very useful feature of the Spectra 2420. ATg or ATG will provide a display of signal levels received within the operating environment and frequency range of the modem under test. ATg averages 256 samples, ATG 16,000.

Invoking the ATg command causes the Spectra 2420 to sweep the operating band and provide a display of both the mean and peak signal levels, in dBm, found on each channel.

The 'graphical' display is limited from -110dBm to -53dBm, and is in 1dB increments. Ignore the leftmost asterisk in calculations (as below).

How to interpret the display (example):

```

...
ch 78 -137dBm *          No signal was measured on channel 78.
ch 80 -105dBm *****... Mean signal level: -(110-5 (asterisks)) = -105dBm
...                      Peak signal level: -(110-5 (asterisks) -3 (dots)) = -102dBm

```

Channel 1 is at 2.4016GHz, with subsequent channels in 400kHz increments up to Channel 202 at 2.4820GHz. Therefore, to calculate the frequency of channel n : $\text{Freq channel } n = 2401.6 + ((n-1) \times 0.400)\text{MHz}$.

6.0 Configuration

In Identification

The I command returns information about the Spectra 2420.

- 1 Product Code (MHX-2420)
- 2 Issue ROM Check (OK or ERROR)
- 3 Product Identification (Firmware Version)
- 4 Firmware Date
- 5 Firmware Copyright
- 6 Firmware Time
- 7 Serial Number

- 255 Factory-Configured Options listing

6.0 Configuration

N Advanced Spectrum Analyzer

The Advanced Spectrum Analyzer feature provides for a very detailed analysis of a particular area of the radio frequency spectrum within which the Spectra 2420 operates.

The specific start (of scan) and stop frequencies, along with step (increment) size and dwell (on frequency) time are user-definable.

Following is the format for the ATN command:

In Command Mode

ATN F_{start} F_{stop} S D[Enter]

where

- F_{start} = start frequency in MHz (including 0-6 decimal places)
- F_{stop} = stop frequency in MHz (including 0-6 decimal places)
- S = step increment in kHz (from 1-1000)
- D = dwell time in ms (from 1-1000)

Example:

ATN 2410.250 2420.500750 25 100

Note: Be sure to enter spaces as shown in the format detailed above.

O Online Mode

Upon completion of tasks being done with the modem in Command Mode, invoking this command will place the modem back 'online' (into Data Mode).

6.0 Configuration

&Fn Load Factory Default Configuration

See Section 5.0 for detailed information on the various factory default options.



Slow Mode is an option for the Spectra 2420.

If the modem being configured does not support Slow Mode, do not load a Slow Mode factory default configuration.

Values

- 1 PMP Master
- 2 PMP Slave
- 3 PMP Repeater
- 4 Slow Mode PMP Master
- 5 Slow Mode PMP Slave
- 6 PTP Master
- 7 PTP Slave
- 8 Slow Mode PTP Master
- 9 Slow Mode PTP Slave

6.0 Configuration

&H0

Frequency Restriction

By default, the Spectra 2420 will hop on frequencies across the entire 2.400-2.4835GHz ISM band. For some applications or within certain operating environments, it may be desired to prohibit the modem from operating on specific frequencies or range(s) of frequencies. The modem will not allow 'too many' frequencies to be restricted; it requires a certain amount of bandwidth within which to operate to comply with regulations.

Following is an example of entering Frequency Restrictions on a Spectra 2420 modem. First, the AT&H0 command is invoked:

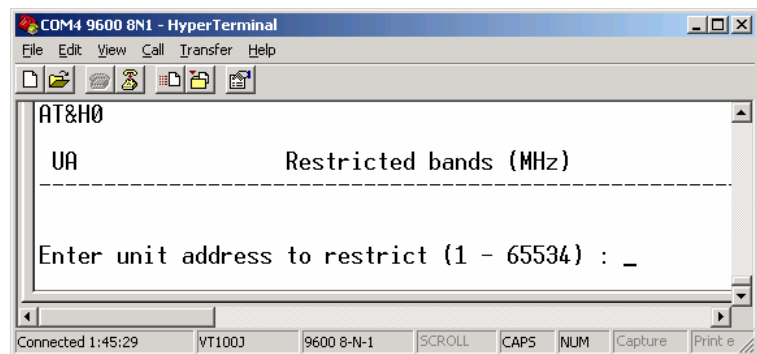

Image 7



All modems in the network must have the same frequency restriction configured within them.



Use the ATg or ATG feature to help identify the frequency/range of possible interfering signals within the 2.400-2.4835GHz ISM band, and then use the AT&H0 feature to configure the modem to avoid them.

The modem responds with a prompt for the Unit Address.

(Enter the Unit Address for the Master (1) and all Repeaters in the network into each modem in the network.)

6.0 Configuration

&H0 Frequency Restriction (continued)

Having entered '1', the modem prompts for the first restricted frequency to be entered.

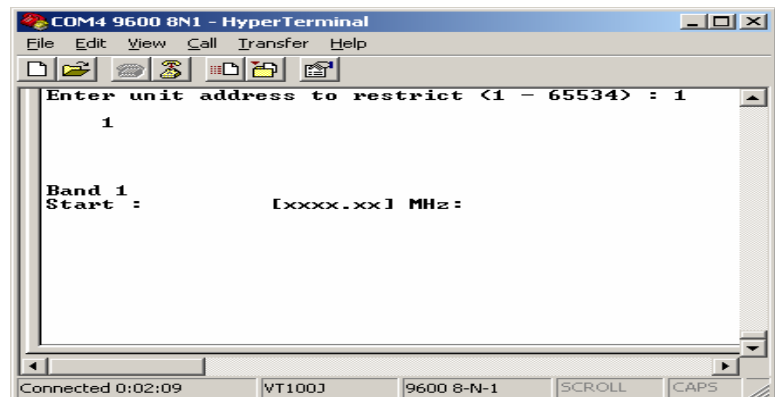

Image 8

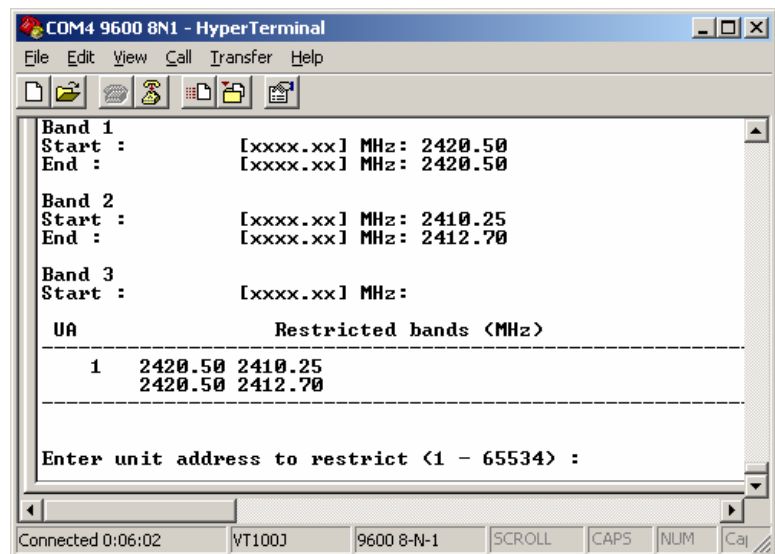

Image 9



To modify an existing restriction, simply overwrite it.

To remove a restriction, overwrite it with 0000.00.

2420.500 was entered as the 'start' and 'end' of Band 1; this will restrict the frequency of 2420.500MHz.

The range of 2410.250 to 2412.700MHz was defined as the second (Band 2) restriction.

When prompted to enter Band 3, the [Esc] key was entered to escape the entry process and the summary at left/bottom was displayed.

Pressing [Esc] again saves and exits the process.

6.0 Configuration

&H1

Repeater Registration

When more than one Repeater exists in a network, the Unit Address of each Repeater should be registered within **every modem** in the network. The reason for doing this is to enable the modems to create hopping patterns which will be orthogonal to each other, thereby minimizing possible interference between network segments.

Upon entering the AT&H1 command, the modem prompts as follows:

- **A** to add a Repeater (this is done by entering the Unit Address of the Repeater)
- **R** to remove a Repeater
- **C** to clear all registered Repeaters.

Pressing the [Esc] key saves and exits the process.

&V

View Configuration

Displays S Register names and current values.

&W

Write Configuration to Memory

Stores active configuration into the modem's non-volatile memory.

6.0 Configuration

6.2 Settings (S) Registers

The majority of modem configuration is done via the Settings (S) Registers.

Section 5.0 provides information on the available factory default settings as related to operating modes and network topologies; this section examines each S register in detail. Appendix C is a quick reference for the S register options.

In the following descriptions, default settings (where applicable) are in **boldface**. In Command Mode,

query format : **ATS<S register #>?** [Enter]

change format : **ATS<S register #>=<value>** [Enter]



If the command referenced by *y* (above) is found to be italicized in the following register descriptions, it indicates that the particular command will not appear in the AT&V (view configuration) display.

y <command> command name> *x*

S0 Auto Answer

This register determines in which mode the modem will be upon power-up.

If selected to power-up in Command Mode, the modem will be offline from the wireless network, and ready to be configured upon power-up.

The typical mode of operation is for the modem to power-up in Data mode: ready to participate in data transfer over the wireless network.

Values

0 up in Command Mode

1 up in Data Mode



Modification of S1 may be required when operating the Spectra 2420 via a telephone modem connection.

S1 Escape Code

Escape character. If >127, escape feature is disabled. Changes to S1 cannot be saved to non-volatile memory.

Modification of this register may be necessary when connecting the modem to a telephone modem where the +++ character string may result in undesired consequences.

Values

any ASCII value

+ (decimal 43)

6.0 Configuration



Note re nomenclature:

A 'Remote' (non-Master) modem is either a Repeater or a Slave.

If a Repeater is not being used as a Repeater/Slave (i.e. there is no device attached to its local data port), leave its handshaking OFF (&K0) and set the serial baud rate (S102) to 115200bps.

S101

Operating Mode

The operating mode defines the role of a modem. A Spectra 2420 modem may be configured for any role required within a radio network. This is convenient for reasons of familiarity with any/all units, as well as for hardware sparing purposes.

The default operating mode is dependent on which factory default option is selected.

MASTER: Only one per network. In all network types (see S133) data either originates at, is destined to, or 'passes through' the Master.

REPEATER: May act simply as a 'Repeater' to store and forward data to/from an upstream unit to/from a downstream unit (e.g. when there is a long distance between the latter units), or, may act as a Repeater/Slave in which case the above function is performed AND the unit may also exchange data as a Slave within the network.

If 1 or more repeaters are to be in a network: see Section 6.2, S141.

If 2 or more repeaters are to be in a network: see Section 6.1, AT command &H1.

SLAVE: Interfaces with remote devices and communicates with Master either directly or via Repeater(s). Communications between 2 or more Slaves is possible - through the Master - see S133 and Section 5.3, 5.4.

Values

- 0 Master
- 1 Repeater
- 2 Slave

6.0 Configuration

102

Serial Baud Rate

The serial baud rate is the rate at which the modem is to communicate with the attached local asynchronous device.



Note: Most PC's do not readily support serial communications greater than 115200bps.

Values

bits per second (bps)

0	230400	8	7200
1	115200	9	4800
2	57600	10	3600
3	38400	11	2400
4	28800	12	1200
5	19200	13	600
6	14400	14	300
7	9600		

S103

Wireless Link Rate

This register determines the rate at which RF communications will occur over a given network.

All modems within a particular network must be configured with the same wireless link rate.

Faster link rates result in greater throughput, however, for each 'step' increase in link rate, there is an approximately 1dB reduction in sensitivity.

Values

bits per second (bps)

0	19200*
1	115200
2	172800
3	230400
4	270000**
5	340000**

* 'slow mode' (optional)

** 'high-speed mode' (optional)

6.0 Configuration



Change the default value for the Network Address to something unique for your network. Do this for an added measure of security and to differentiate your network from others which may be operating nearby.

S104

Network Address

All modems in a given network must have the same Network Address. This unique network address is not only a security feature for a particular network, but also allows other networks - with their own unique network address - to operate in the same area without the possibility of undesired data exchange between networks.

Values

0-4,000,000,000

1234567890

S105

Unit Address

The unit address is, and must be, a unique identifier of each modem in a network. The address value is 16-bits in length.

The Master has by default, and must retain, a unit address of 1; 65535 is the broadcast address.

Values

2-65534

6.0 Configuration



Change S107 to something unique for your network.

S107

Static Mask

This mask is applied to the transmitted data, and removed from the received data. It is an added form of security for a network.

If you require Strong Encryption, 128-bit AES Encryption contact Microhard Systems for Part Numbers and Export Restrictions.

Values

up to 16 characters

default (the word itself)

6.0 Configuration

S108

Output Power

This setting establishes the transmit power level which will be presented to the antenna connector at the rear of the modem.

Unless required S108 should be set not for maximum, but rather for the minimum value required to maintain an adequate system fade margin.



FCC regulations allow for up to 36dBi effective isotropic radiated power (EIRP). The sum (in dBm) of the transmitted power, the cabling loss, and the antenna gain cannot exceed 36dBi.

Values

dBm (mW equivalent)

20	(100)
21	(125)
22	(160)
23	(200)
24	(250)
25	(320)
26	(400)
27	(500)
28	(630)
29	(800)
30	(1000)

6.0 Configuration

S109

Hop Interval

This register is effective only on the Master and is responsible for establishing the rate at which all modems within a particular network change frequency (hop - from frequency to frequency).

Long hop intervals typically result in the greatest data throughput, however shorter hop intervals may decrease latency, particularly of smaller packets of data.

The default setting of 20ms is satisfactory for most applications. If adjustment of S109 is being considered, also consider the serial baud rate, wireless link rate, and maximum packet size (S102, S103, and S112).

Values

milliseconds (ms)

0	1.5	10	30
1	2.0	11	40
2	2.5	12	50
3	3.0	13	60
4	4.0	14	70
5	5.0	15	80
6	7.0	16	90
7	10	17	100
8	15	18	125
9	20	19	150

6.0 Configuration

S110

Data Format

This register determines the format of the data on the serial port. The default is 8 data bits, No parity, and 1 Stop bit.

Values

1	8N1	6	7N2
2	8N2	7	7E1
3	8E1	8	7O1
4	8O1	9	7E2
5	7N1	10	7O2

S112

Packet Max Size

Determines that maximum number of bytes from the connected device that should be encapsulated into a packet.

Large packet sizes may produce the best data throughput; however, a smaller packet is less likely to become corrupted and, if it does, is retransmitted with a lesser impact on network traffic.

The default setting of 255 bytes is suited to most applications. If adjustment of S112 is being contemplated, take into consideration such factors as data rate, wireless link rate, and the hop interval (S102, S103, S109).

Values

bytes

0-255

255

6.0 Configuration



In a PMP system, set S113 to the minimum value required as, effectively, the data throughput from Master to Remote is divided by 1 plus the number stored in S113.

S113

Packet Retransmissions

This register determines the maximum amount of times that a packet will be retransmitted (in addition to the initial transmission), noting the following specific behaviours in various network topologies:

PMP: Master will retransmit each data packet the exact number of times specified in its S113; Slave will retransmit only if necessary, and then only until a given packet is acknowledged or the value of the Slave's S113 is reached (after which it will discard the packet if retransmission not successful).

PTP: Modem will retransmit to its counterpart only if necessary, and to a maximum number of the value in S113. Packet is discarded if retransmissions are not successful.

Recipients of packets will discard any duplicates.

Values

0-255

5

6.0 Configuration

S115

Repeat Interval

S115 determines the number of slots which are available within a window of opportunity for Remote units to submit channel requests to the Master modem.

For a large number of remotes, particularly if there may be concurrent demand for Remotes to desire to send information to the Master, the value of S115 should be set relatively high: Remotes will randomly contend for the ability to access the channel request slots.

For a small number of Remotes, particularly if their need to transmit data to the Master is quite random, it is advisable to keep S115 closer to the default value so as to not 'waste bandwidth' by maintaining a relatively large window housing a greater-than-necessary number of channel reservation request slots.

In a TDMA-type system, S115 may be set to 1 as the Remotes are not able to request a transmission channel: the Master polls each Remote for data.

Values

hop intervals
1-255

3

6.0 Configuration

S116

Character Timeout

This 'timer' looks for gaps in the data being received from the local attached device. The timer is activated after the Minimum Packet Size (S111, default 1 Byte) has been accumulated in the modem, after which, if the timer detects a gap in the data exceeding the Character Timeout value, the modem will transmit the data.

The Spectra 2420 will accumulate data in its buffers until either (a) Maximum Packet size (S116) has been accumulated, or (b) Minimum Packet Size (S111) has been accumulated AND the Character timeout has expired—whichever occurs first.

If S116 is set to 0ms, the modem will buffer exactly the Minimum Packet size and then transmit that data.

Values

ms
0-254

10

6.0 Configuration



When bench testing 3 modems for a Master-Repeater-Slave link, be sure to set the Slave's S118 to the UA of the Repeater, and the Repeater's S118 to the UA (1) of the Master.

This will ensure that data is routed from the Slave through the Repeater to the Master; otherwise, if the Slave's S118 is left at the default value of 1, the Slave will communicate directly with the Master, bypassing the Repeater altogether.

S118

Roaming

This feature allows a Remote unit to synchronize with a specified 'upstream' unit (either Master or Repeater). The options are as follows:

S118=65535: With this value in its S118 register, a Remote will synchronize with an upstream unit which has the same network address (S104) and static mask (S107) as the Remote. Should that upstream unit fail, this Remote will attempt to synchronize with another 'upstream' unit within the same network. This ability is particularly well-suited to mobile applications.

S118=1-254: In most static (fixed) networks, where there are no Repeaters, the default value of 1 is maintained: All Slaves synchronize to the Master (whose unit address is 1).

In networks where Repeaters are present, the value of a Remote's S118 corresponds to the particular upstream modem with which a particular Remote is intended to communicate, e.g. Slave UA (S105)=3 may have an S118=2, where the modem with UA 2 is a Repeater between the Slave and the Master; the Repeater will have an S118=1.

S118 dictates which modem (by Unit Address (UA)) a Remote unit will 'look' or 'attach to' for its upstream signal path.

Values

65535 full roaming

1-254 specific (fixed) unit address (Master or Repeater) with which to associate

1

6.0 Configuration

S119 Quick Enter to Command Mode

If this register is set to 1, a delay of 5 seconds is introduced at power-up before the modem will go into Data Mode. If, during these 5 seconds, the user enters 'mhx' the modem will instead go into Command Mode and reply with 'OK'. The terminal baud rate must be set to 9600bps. If an incorrect character is entered, the modem will immediately go into Data mode.

The default setting is 0: The modem will promptly go into Data Mode upon power-up.

Values

0 disabled
1 enabled

6.0 Configuration



A Master modem's RSSI LEDs will not illuminate to any degree until such time as it has received valid packets from a 'downstream' unit. Also, should the downstream unit(s) fail, a Master will maintain the last RSSI reading display.

S123

Average RSSI

This register displays (it is not a 'setting') the average signal strength received over the previous 4 hop intervals. The value in this register is also reflected in status lines RSSI1, 2, and 3, which connect to the modem's front panel RSSI LEDs.

Values

dBm
-110 to -55dBm (maximum reading)



ALL modems in a network must have the SAME value for Network Type.

S133

Network Type

Defines the type of network (see Section 5.0 for a detailed description of network topologies).

In a point-to-multipoint (PMP) network, the Master broadcasts data to all units, and all remote units send their data (ultimately) to the Master.

A point-to-point (PTP) network involves a Master and a Slave (with 0 or more Repeaters inbetween).

Peer-to-Peer involves either communication between 2 (typically remote) units (P2P) or between all units (everyone-to-everyone - E2E).

Values

0 Point-to-Multipoint
1 Point-to-Point
2 Peer-to-Peer or Everyone-to-Everyone

6.0 Configuration

S140 Destination Address

As the name implies, this register specifies the ultimate destination for a modem's data.

Different network topologies dictate the configuration of S140:

PMP : Master S140=65535, Remote S140=1

PTP : Master S140=UA of Remote, Remote S140=1

P2P : Master S140=65535, S140 of each (of 2 / pair) Remote modem is the UA of the other

E2E : S140 of all modems=65535 (broadcast)

Values

1-65535



With one or more Repeaters in the system, a network's throughput is divided in half. Exercising the option of back-to-back 'Repeaters' - which requires 2 modems at a 'Repeater' site - eliminates the division of bandwidth.

If there is more than one Repeater in a network, the Repeaters should be 'registered'. See Section 6.1 AT&H1 Repeater Registration for how to accomplish this.

S141 Repeaters Y/N

This register informs - and applies only to - the Master as to the presence of any Repeater(s) in the network.

Values

0 no repeater
1 1 or more repeaters

6.0 Configuration

S142

Serial Channel Mode

This register defines the physical serial interface which will be used for data communications.



Note: When placed into Command Mode, the modem will communicate via the RS-232 interface at 9600bps, 8N1.

Values

- 0 RS-232 interface
- 1 half-duplex RS-485
- 2 full-duplex RS-485

6.0 Configuration

S143

Sleep Mode

This register applies only to Remote (i.e. not Master) modems, and determines if the Remote should remain active continuously (S143=0, default), or enter a timer-based sleep mode.

Sleep Mode 1

To awaken modem:

1. Apply 5VDC to WAKEUP! input of MHX2420 module (within the Spectra 2420 enclosure).
2. Modem fully awakens when there is incoming data on local data port; stays awake (active) when there is data on local data port or incoming via the RF link.

Sleep Mode 2

To awaken modem:

Same as above, except the modem will not stay awake on data incoming via RF link; unit will go back to sleep when Wake Time (S143) expires.

Sniff Mode 1

Remote in this mode awakens when data on local data port. Modem will try to find an upstream unit (Master or Repeater) for a brief period of time defined by S237. If upstream unit is found, modem stays awake for Wake Time (S145), if upstream unit not found, modem will go to sleep for Sleep Time (S144). Sniffing cycle is very brief; unit stays awake only when there is data on local data port or until such time as all data to be transmitted is transmitted.

Sniff Mode 2

Same as Sniff Mode 1 except modem will remain awake only when there is data on local data port (i.e. over-the-air data will not keep unit awake).

6.0 Configuration

S143

Sleep Mode (continued)

Sniff Mode 3

Same as Sniff Mode 1 except data will be discarded if modem cannot find upstream unit.

Values

- 0 active (no sleep)**
- 1 sleep mode 1
- 2 sleep mode 2
- 3 sniff mode 1
- 4 sniff mode 2
- 5 sniff mode 3

6.0 Configuration

S144

Sleep Time

This register applies only to Remote modems and is only effective when S143>0.

Defines sleep duration for up to approximately 18 hours.

Two conditions will awaken a Remote: 1. sleep duration time has expired, or 2. incoming data on local data port.

When a sniff mode is selected (S143), the modem will start its sniff cycle when the Sleep Time expires or will wake up completely when there is data on its local data port.

Values

seconds

0-65535

60

6.0 Configuration



The most effective way to put an entire network into sleep/sniff mode is by turning off, or putting into command mode, the Master modem.

S145

Wake Time

Applies only to Remote modems and effective only when S143>0. This register determines how long a modem will stay awake after the local data port and radio links become idle.

When the modem is idle for the amount of time specified in S145, it will go to sleep; it will go to sleep immediately if 'upstream' unit is offline or goes into sleep/sniff mode.

Values

seconds

0-65535

10

S149

LED Brightness

This is a power saving feature which controls the current available to LEDs such that they operate with from 0% (off) to 100% available brightness.

It is recommend to set S149 to 100 for testing in a shop environment, and then reduce the value as required when deploying in the field where power consumption may be of concern.

Values

percent (%)

0-100

100

6.0 Configuration

S150

Sync Mode

This setting applies only to the Master modem. S150 dictates which sync mode the Master will use when it initially goes online. Quick sync mode results in the Master hopping very quickly, which will enable a downstream unit to become synchronized faster.

A setting of 1 applies only in a point-to-point (PTP) configuration: the Master will stay in quick sync mode until such time as it receives an acknowledgement from its associated Slave, it will then remain hopping quickly for the number of hop intervals (8-255) defined by S152 (Fast Sync Hold on Ack), after which time it will go into normal sync mode.

A value of 2 results in the Master going into quick sync mode when it initially comes online and then remaining in that mode for the duration specified in S151 (fast sync timeout) and then return to normal sync mode.

Values

- 0 normal sync
- 1 quick sync mode, wait for acknowledgement
- 2 quick sync mode, wait for timeout

S151

Fast Sync Timeout

This register settings applies only to a Master modem. Effective only when S150=2.

Defines how long, in milliseconds, a Master modem will stay in fast sync mode after it initially goes online.

Values

milliseconds (ms)

100-65000

200

6.0 Configuration

S153

Address Tag

If enabled, the modem prepends 4 extra bytes to the data: first byte = 0x00, second = 0xFF, third = source unit address (high byte), fourth = source unit address (low byte).

Value

0 **disable**
1 **enable**

6.0 Configuration

S158 FEC (Forward Error Correction) Mode

A number of FEC schemes are available with different coding rates.

FEC does consume bandwidth: depending on which coding rate is chosen, a number of coding bits are transmitted along with the 'data' bits.

In 'noisy' or long-range communications environments, FEC may effectively increase throughput by decreasing the amount of packet retransmissions which would otherwise be required.

Communications range may also be extended with the use of FEC: at a certain distance where data would otherwise be unacceptably corrupted, employing FEC may be all that is required to maintain the integrity of that data at that distance.

Types of FEC available within the Spectra 2420:

Hamming (7,4)	:	Information rate 0.5, corrects 1 out of 7 bits
Hamming (15,11)	:	Information rate 0.66, corrects 1 out of 15 bits
Hamming (31,24)	:	Information rate 0.75, corrects 1 out of 31 bits
Binary BCH (47,36)	:	Information rate 0.75, corrects 2 bits
Golay (23, 12, 7)	:	Information rate 0.75, corrects 3 bits
Reed-Solomon (15,11)	:	Information rate 0.687, corrects 2 nibbles



If throughput is not of primary concern and there is an emphasis on providing the most robust data communications, FEC should be considered.

Values

- 0 No FEC**
- 1 Hamming (7,4)
- 2 Hamming (15,11)
- 3 Hamming (31,24)
- 5 Binary BCH (47,36)
- 6 Golay (23,12,7)
- 7 Reed-Solomon (15,11)

6.0 Configuration

S217

Protocol Type

For most applications, the default value of 0 - resulting in transparent operation - will be maintained in this register.

Setting this register to a value of 1 specifies MODBUS operation, in which the modem will frame the output data and comply with MODBUS specifications.

S217=2 configures the modem for DF1 filtering. In this mode, the PLC's address must match the Unit Address of the modem. Data not intended for a specific PLC/Modem pairing will be blocked from passing through the modem to the attached PLC.

Values

- 0** transparent
- 1 MODBUS RTU
- 2 DF1 protocol, full-duplex, with address filtering

6.0 Configuration



The longer the Sniff Timeout (duration), the more assured it is that the Remote modem will 'find' an upstream unit when it is desired to wake up the system, however more power will be consumed.

S237

Sniff Timeout

This register applies only to Remote modems. Defines how many hops the unit will sniff for upon expiry of the Sleep Time (S144).

The Sniff Timeout (sniff duration) in milliseconds is calculated as follows:

Sniff Timeout = S237 (hops) x hop interval (per S109)

Example: S237=20, S109=9 (=20ms)

Sniff Timeout = 20 (hops) x 20ms per hop = 400ms

Values

hops

1-255

10

6.0 Configuration

S244

Channel Request Mode

Channel Request Mode 'on' (default), allows a Remote modem which has data to send to request from the Master permission to do so. When granted, the Remote will be allowed to transmit all of its data (no other Remotes may transmit during this period), upon completion of which it will release the channel. This feature eliminates collisions which would otherwise occur if a number of Remotes were all trying to transmit at the same time (e.g. if S244=2).

TDMA mode is discussed in detail in Section 5.2.1. It relates to Channel Requests in that, in TDMA mode, the Master does not allow such requests from Remotes; the Master sequences through a list of Remotes, giving each one in turn an opportunity to transmit.

Values

- 0 Channel Request**
- 1 TDMA Mode
- 2 No Channel Request

6.0 Configuration

S251

Master Hop Allocation Timeout

In TDMA mode (see S244 and Section 5.2.1) this register determines how long, in hop intervals, the Master will wait for a Remote to either (a) begin to send data or (b) indicate that it has completed sending all of its data, prior to the Master sequencing to the next Remote to be given permission to transmit.



In a 'clean' RF environment, it may be of benefit to reduce S251 to 2 or 3 as, should a Remote be unable to communicate for some reason, the 'wait' time for the Master to proceed to poll the next Slave would be reduced.

Values

hops

1-254

10

6.0 Configuration

6.3 Serial Interface Commands

A number of register settings are specifically related to the serial data interface. Some, which have been discussed previously, include:

S102 Serial Baud Rate

determines the rate of communications between the modem and the local device

S110 Data Format

defines the data, stop, and parity bit count

S142 Serial Channel Mode

selects the actual serial interface to be used

S217 Protocol Type

defines the nature of the incoming data and what, if any, special action should be taken by the modem upon the data

Also, there are AT commands which effect the configuration of the modem, specifically with respect to the handling of data at the RS-232 interface:

&C Data Carrier Detect (DCD)

&D Data Terminal Ready (DTR)

&K Handshaking

&S Data Set Ready (DSR)

The above four items are discussed further in this section.

6.0 Configuration

&Cn Data Carrier Detect (DCD)

Controls the modem's DCD output signal to the attached device. Determines when the DCD line is active.

Values

- 0 DCD always on
- 1 **DCD on when modems synchronized***
- 2 DCD used for output data framing and Modbus mode
- 3 On Slave units, DCD will pulse for 2ms each time valid sync packet received from Master which sends 1 sync packet per hop

*DCD always on when modem configured as a Master

6.0 Configuration

&Dn Data Terminal Ready (DTR)

Controls the action that the modem will perform when the DTR input line's state is modified.

Values

- 0 **DTR ignored**
- 2 deassert DTR to force modem into Command mode (at serial baud rate set by S102); DTR must be reasserted before putting modem back into data mode (normally done using ATA command)

&Kn Handshaking

Enables or disables hardware handshaking.



Software flow control (XON/XOFF) is not supported.

Values

- 0 **handshaking disabled**
- 3 RTS/CTS handshaking enabled

6.0 Configuration

&Sn

Data Set Ready (DSR)

Controls the modem's DSR line and determines when it is active.

Values

- 0 DSR always on
- 1 ON in Data mode, OFF in Command mode
- 2 DTR/DSR signaling:
Remotes output state of Master's DTR on their local DSR line in PMP network. Master only outputs state of Slave's DTR on its local DSR line in PTP. Not supported in P2P or E2E network.

7.0 Installation



The installation, removal, or maintenance of any antenna system components must be undertaken only by qualified and experienced personnel.

There are a number of factors to consider when preparing to deploy a radio network, several of which have been touched-upon or detailed elsewhere within this manual. Following is a listing of a number of factors, in no particular order:

Network Topology

Section 5.0 detailed the various network topologies which the Spectra 2420 will support. Determine which topology is suited to your specific requirements.

Throughput

The Spectra 2420 is capable of 230.4kbps asynchronous serial data throughput. The network topology has an effect on how this available throughput is 'shared' between all nodes on the network.

Distance

The physical distance between the modems dictates such things as required antenna performance and heights, and whether or not a Repeater(s) is required. When contemplating antenna types and Repeater sites, keep in mind the directivity (omnidirectional or directional) of the antennas being used, and also recall the effect of a Repeater on throughput (see Section 4.4).

Terrain

Along with distance, the terrain is a very important consideration with respect to antenna height requirements. The term 'line-of-sight' (LOS) refers to being able to 'see' one location from another - a minimum requirement for a radio signal path. In addition to LOS, adequate clearance must also be provided to satisfy 'Fresnel Zone' requirements - an obstruction-free area much greater than the physical LOS, i.e. LOS is not enough to completely satisfy RF path requirements for a robust communications link.

7.0 Installation

Transmit Power

Having read thus far through the factors to be considered, it should be clear that they are all interrelated. Transmit power should be set for the minimum required to establish a reliable communications path with adequate fade margin. Required transmit power is dictated primarily by distance, antenna type (specifically the 'gain' of the antennas being used), and the receive sensitivity of the distant modem. Cable and connector losses (the physical path from the modem's 'antenna connector' to the antenna's connector) must also be taken into account.

Receive Sensitivity

The Spectra 2420 has exceptional receive sensitivity, which can produce a number of benefits, such as: added fade margin for a given link, being able to use less expensive coaxial cable or antenna types, being able to operate at greater distances for a given distant transmitter power (perhaps negating the requirement for a Repeater site!). Distance, antenna gain, transmit power, and receive sensitivity are critical 'numbers' for radio path calculations. Fortunately, the Spectra 2420 features the maximum available transmit power combined with exceptional receive sensitivity - two 'numbers' which will produce the most favorable path calculation results.

Fade Margin

When all radio path numbers are being considered and hardware assumptions are being made, another factor to consider is the 'fade margin' of the overall system. The fade margin is the difference between the anticipated receive signal level and the minimum acceptable receive level (receive sensitivity). Being that the Spectra 2420 performs to exacting specifications, the overall deployment should be such that the modems may be utilized to their full potential to provide a reliable and robust communications link. A typical desired fade margin is in the order of 20dB, however often times a 10dB fade margin is acceptable.

Frequency

The 2.4GHz frequency range is effected by rain to some degree. Path calculations provide results which specify 'required' antenna heights. For cost savings, sometimes the height requirements are not adhered to: this may result in unreliable communications.

7.0 Installation

Power Requirements

The Spectra 2420 accepts a range of DC input voltages (keep in mind that supply current requirements must also be met). In some deployments, power consumption is critical. A number of features related to minimize power consumption are available with the Spectra 2420: sleep/sniff modes, LED dimming, and the ability to operate at less transmit power given the receive sensitivity of the distant modem.

Interference

The frequency hopping spread spectrum (FHSS) operation of the Spectra 2420 modem most often allows it to work well in an environment within which there may be sources of inband interference. Frequency Restriction is a built-in feature which may be utilized to avoid specific frequencies or ranges of frequencies; the Spectrum Analyzer function may be used to identify areas of potential interference.

7.0 Installation



FCC regulations allow for up to 36dBi effective isotropic radiated power (EIRP). The sum (in dBm) of the transmitted power, the cabling loss, and the antenna gain cannot exceed 36dBi.

7.1 Path Calculation

Assuming adequate antenna heights, a basic formula to determine if an adequate radio signal path exists (i.e. there is a reasonable fade margin to ensure reliability) is:

$$\text{Fade Margin} = \text{System Gain} - \text{Path Loss}$$

where all values are expressed in dB.

As discussed on the previous page, a desired fade margin is 20dB.

System gain is calculated as follows:

$$\begin{aligned} \text{System Gain} = & \text{Transmitter Power} + (\text{Transmitter Antenna Gain} - \\ & \text{Transmitter Cable and Connector Losses}) + \\ & (\text{Receiver Antenna Gain} - \text{Receiver Cable and} \\ & \text{Connector Losses}) + | \text{Receiver Sensitivity} |. \end{aligned}$$

where all values are expressed in dB, dBi, or dBm, as applicable.

Example:

Tx power = 30dBm
 Tx antenna gain = 6dBi
 Tx cable/connector loss = 2dB
 Rx antenna gain = 6dBi
 Rx cable/connector loss = 2dB
 Rx sensitivity = -106dBm

$$\begin{aligned} \text{System Gain} &= 30+(6-2)+(6-2)+106 \\ &= 30+4+4+106 \\ &= 144\text{dB}. \end{aligned}$$

Assuming a path loss of 113dB for this example, the fade margin = 144-113 = 31dB. 31dB exceeds the desired fade margin of 20dB, therefore this radio communications link would be very reliable and robust.

On the following page are examples of actual path loss measurements taken in an open rural environment; the path loss numbers do not apply to urban or non-LOS environments.

7.0 Installation



To satisfy FCC radio frequency (RF) exposure requirements for mobile transmitting devices, a separation distance of 20cm or more should be maintained between the antenna of this device and persons during device operation. To ensure compliance, operation at less than this distance is not recommended. The antenna used for this transmitter must not be co-located in conjunction with any other antenna or transmitter.



Never work on an antenna system when there is lightning in the area.

Distance (km)	Master Height (m)	Remote Height (m)	Path Loss (dB)
5	15	2.5	123.5
5	30	2.5	117.9
8	15	2.5	131.1
8	15	5	124.7
8	15	10	112
16	15	2.5	142.3
16	15	5	135.9
16	15	10	123.2
16	30	10	116.6
16	30	5	129.4
16	30	2.5	135.8

Table 5: Path Loss

Once the equipment is deployed, average receive signal strength may be determined by accessing S Register 123.

7.2 Installation of Antenna System Components

The installation, removal, or maintenance of any antenna system components must be undertaken only by qualified and experienced personnel.

7.0 Installation

7.2.1 Antennas



Direct human contact with the antenna is potentially unhealthy when a Spectra 2420 is generating RF energy. Always ensure that the Spectra 2420 equipment is powered down (off) during installation.

The two most common types of antenna are the omnidirectional ('omni') and directional (Yagi).

An **omni** typically has 3-6dBi gain and spreads its energy in all directions (hence the name 'omnidirectional'). The 'pattern' of the energy field is in the shape of a donut, with the antenna mounted vertically at the centre. This vertical-mounted antenna produces a signal which is vertically 'polarized'.

A **Yagi** has a more focused antenna pattern, which results in greater gain: commonly, 6-12dBi. The pattern of a Yagi is in the shape of a large raindrop in the direction in which the antenna is pointed. If the elements of the Yagi are perpendicular to the ground (most common orientation) the radiated signal will be vertically polarized; if parallel to the ground, the polarization is horizontal.

The network topology, application, and path calculation are all taken into consideration when selecting the various antenna types to be used in a radio network deployment.

In a long-range PTP network, Yagi antennas should be considered. These antennas will provide for the most focused 'RF connection' between the two sites.

In a PMP network where Remotes are located in all directions from the Master, the Master site will have an omni so that it can communicate with all Remotes; the Remotes, however, may all employ Yagi antennas 'pointed at' the Master.

Typically a Repeater site will employ an omni such that it can readily receive an RF transmission from one direction and be able to readily transmit it in another.

If an application involves Remotes which are not stationary (e.g. mobile application), all sites would likely use omni antennas so that wherever the units may be, there should be antenna pattern coverage.

7.0 Installation



To comply with FCC regulations, the maximum EIRP must not exceed 36dBm.

The path calculation (see Section 7.1) will determine the antenna gain requirements. Refer to the beginning of this section to review the various factors which must be considering when deploying a network. Do not discount the importance of the REQUIRED HEIGHT for the antennas within your network.

7.2.2 Coaxial Cable

The following types of coaxial cable are recommended and suitable for most applications (followed by loss at 2.4GHz, in dB, per 100 feet):

- LMR 195 (19)
- LMR 400 (6.8)
- LMR 600 (4.4)

For a typical application, LMR 400 may be suitable. Where a long cable run is required - and in particular within networks where there is not a lot of margin available - a cable with lower loss should be considered.

When installing cable, care must be taken to not physically damage it (be particularly careful with respect to not kinking it at any time) and to secure it properly. Care must also be taken to affix the connectors properly - using the proper crimping tools - and to weatherproof them.

7.0 Installation

7.2.3 Surge Arrestors

The most effective protection against lightning-induced damage is to install two lightning surge arrestors: one at the antenna, the other at the interface with the equipment. The surge arrestor grounding system should be fully interconnected with the transmission tower and power grounding systems to form a single, fully integrated ground circuit.

Typically, both ports on surge arrestors are N-type female.



All installation, maintenance, and removal work must be done in accordance with applicable codes.

Appendix A: Approved Antennas

Group	Part Number	Description
Rubber Ducky		
	MHS031100	2dBi, 2.4GHz Rubber Ducky Antenna RPTNC Swivel
	MHS031110	2dBi, 2.4GHz Rubber Ducky Antenna Reverse SMA Swivel
	MHS031120	2dBi, 2.4GHz Rubber Ducky Antenna Reverse SMA Straight
Transit Antennas		
	MHS031270	3 dBi, 2.4GHz Transit Antenna Magnetic Mount with Ground Plane
	MHS031290	3 dBi, 2.4GHz Transit Antenna Permanent Mount with Ground Plane
	MHS034300	3 dBi, 2.4GHz Compact Omni Antenna w/ Magnetic Base
		<i>Mounts for Transit Antennas have a RPTNC Pigtail</i>
Patch Antennas		
	MHS034200	8 dBi, 2.4GHz Mini Flat Patch Directional Antenna RPTNC Pigtail
	MHS034210	14 dBi, 2.4GHz Flat Patch Directional Antenna RPTNC Pigtail
Yagi Antennas		
	MHS034100	9 dBi, 2.4GHz Yagi Directional Antenna RPTNC Pigtail
	MHS034110	12 dBi, 2.4GHz Yagi Directional Antenna RPTNC Pigtail
	MHS034120	14 dBi, 2.4GHz Yagi Directional Antenna RPTNC Pigtail
	MHS034150	14.5 dBi, 2.4GHz Yagi Directional Antenna RPTNC Pigtail
Omni Directional		
	MHS031260	5 dBi, Omni Directional Antenna RPTNC Pigtail
	MHS034000	6 dBi, 2.4GHz Omni Directional Antenna RPTNC Pigtail
	MHS031340	8 dBi, Omni Directional Antenna RPTNC Pigtail
	MHS034020	10.5 dBi, 2.4GHz Omni Directional Antenna RPTNC Pigtail
	MHS034030	12 dBi, 2.4GHz Omni Directional Antenna RPTNC Pigtail
	MHS034040	15 dBi, 2.4GHz Omni Directional Antenna RPTNC Pigtail



WARNING:

Changes or modifications not expressly approved by Microhard Systems Inc. could void the user's authority to operate the equipment. This device has been tested with MCX and Reverse Polarity SMA connectors with the antennas listed in Appendix A. When integrated in OEM products, fixed antennas require installation preventing end-users from replacing them with non-approved antennas. Antennas not listed in the tables must be tested to comply with FCC Section 15.203 (unique antenna connectors) and Section 15.247 (emissions). Please Contact Microhard Systems Inc. if you need more information.

Industry Canada: This device has been designed to operate with the antennas listed above, and having a maximum gain as indicated. Antennas not included in this list, or having a gain greater than listed, are strictly prohibited for use with this device. The required antenna impedance is 50 ohms. To reduce potential radio interference to other users, the antenna type and its gain should be chosen so that the equivalent isotropically radiated power (EIRP) is not more than that required for successful communication.

Appendix B: AT Command Quick Reference

The following commands may be used when the modem is in COMMAND MODE; all are to be preceded with "AT" and followed with [Enter]. An asterisk (*) indicates a default setting, where applicable.

A

Answer

-this command puts the modem into data mode

Dxxxxx, DTxxxxx, DPxxxxx

Dial

-identical commands which change the unit address to xxxxx and put the modem into data mode

g, G

Spectrum Analyzer

Used to help determine if interfering RF signals are present.

In

Identification

-follow ATI with either of the following 'n':

- 1-product code
- 2-ROM check (OK or ERROR)
- 3-firmware version
- 4-firmware date
- 5-firmware copyright
- 6-firmware time
- 7-serial number
- 255-factory-configured options listing

N

Advanced Spectrum Analyzer

Advanced spectrum analyzer provides for a more detailed scrutiny of the RF environment.

O

Online Mode

-this command puts the modem into data mode

Tx

Registered Slave List (TDMA)

? -view list

Tn=UA -set list number n equal to Remote's Unit Address

Tn? -view list item n

&Fn

Load Factory Default Configuration

-follow AT&F with either of the following 'n':

- 1-MASTER Point-to-Multipoint, use with &F2/&F3 modems
 - 2-SLAVE Point-to-Multipoint, works with &F1
 - 3-REPEATER Point-to-Multipoint, works with &F1/&F2
 - 4-SLOW MODE* MASTER Point-to-Multipoint
 - 5-SLOW MODE* SLAVE Point-to-Multipoint
 - 6-MASTER Point-to-Point, works with &F7
 - 7-SLAVE Point-to-Point, works with &F6
 - 8-SLOW MODE* MASTER Point-to-Point
 - 9-SLOW MODE* SLAVE Point-to-Point
- *SLOW MODE is optional

&Cn

DCD (Data Carrier Detect)

-controls modem's DCD output signal

0-DCD always on

1-*DCD on when modem's sync'ed, always on if Master

2-DCD used for output data framing and Modbus mode

3-Slave: DCD pulses for 2ms when modem receives valid sync pulse from Master (which sends sync pulse once per hop)

&Dn

DTR (Data Terminal Ready)

-controls the action the modem performs when the DTR input line is toggled

-follow ATD with either of the following 'n':

0-*DTR line ignored

2-deassert DTR to force modem from data mode into command mode at S102 serial baud rate; DTR must be asserted before putting modem back into data mode (normally done using 'ATA' command)

&H0

Frequency Restriction

Follow onscreen prompts to input undesired frequencies.

&H1

Repeater Registration

When more than 1 repeater exists in a network, the repeaters should be 'registered' using this command to ensure that frequencies used are orthogonal to each other (thereby minimizing potential interference).

&Kn

Handshaking

-determines handshaking between modem and host device

0-*disable handshaking

3-enable hardware (RTS/CTS) handshaking

&Sn

DSR (Data Set Ready)

-controls modem's DSR line and determines when it is active

0-DSR always on

1-*DSR ON in data mode, OFF in command mode

2-DTR/DSR signaling: slaves and repeaters output state of master's DTR on their local DSR line in PMP mode, master only outputs state of slave's DTR on its local DSR line in PTP network, not supported in P2P or E2E network.

Appendix B: AT Command Quick Reference

AT&V

View Configuration

-displays all visible S registers and their current values

&W

Write Configuration to Memory

-stores active configuration into modem's non-volatile memory

Sxxx?

Read S Register Value

-where xxx is the S register's number, this command will result in displaying the current setting of that register

Sxxx=yyy

Set S Register Value

-where xxx is the S register's number, this command will place value yyy in that register

Appendix C: Settings (S) Register Quick Reference

The registers described in this Appendix are ones which are normally 'visible' to the user. The values stored in these registers effect the operation of the modem. An asterisk * represents default value (if applicable).

Query format : **ATSxxx? [Enter]** where xxx is S register *number* detailed below
 Change format : **ATSxxx=y [Enter]** where xxx is S register number and y is desired value

S0

Auto Answer

0-modem will power-up in command mode
 1-*modem will power-up in data mode

S2

Escape Code

-contains ASCII value of escape character
 -*43' is default value, which represents the ASCII character '+'
 -values greater than 127 disable the escape feature and prevent user from returning to command mode
 -changes cannot be stored to non-volatile memory

S101

Operating Mode

0-Master
 1-Repeater
 2-Slave

S102

Serial Port Baud Rate (bps)

- 0-230400
- 1-115200
- 2-57600
- 3-38400
- 4-28800
- 5-19200
- 6-14400
- 7-*9600
- 8-7200
- 9-4800
- 10-3600
- 11-2400
- 12-1200
- 13-600
- 14-300

S103

Wireless Link Rate (bps)

1-115200
 2-*172800
 3-230400

S104

Network Address

0-4,000,000,000
 *1234567890

S105

Unit Address

2-65534 (master is 1, broadcast is 65535)

S107

Static Mask

-up to 16 characters
 *default

S108

Output Power Level

20-30dBm
 *30 (1W)

S109

Hop Interval (ms)

- 0-1.5
- 1-2.0
- 2-2.5
- 33.0
- 4-4.0
- 5-5.0
- 6-7.0
- 7-10
- 8-15
- *9-20
- 10-30
- 11-40
- 12-50
- 13-60
- 14-70
- 15-80
- 16-90
- 17-100
- 18-125
- 19-150

S110

Data Format (of Asynchronous serial input to modem)

- 1-*8N1
- 2-8N2
- 3-8E1
- 4-8O1
- 5-7N1
- 6-7N2
- 7-7E1
- 8-7O1
- 9-7E2
- 10-7O2

S112

Packet Max Size (bytes)

0-255
 *255

S113

Packet Retransmissions

0-65535
 *5

S115

Repeat Interval

1-255
 *3

Appendix C: Settings (S) Register Quick Reference

S118

Roaming

65535-roaming enabled
1-254-fixed upstream unit
*1

S119

Quick Enter to Command Mode

0-*disabled
1-enabled

S123

RSSI Value (dBm, read only)

S133

Network Type

0-Point-to-Multipoint (PMP)
1-Point-to-Point (PP)
2-Peer-to-Peer (P2P)

S140

Destination Address

1-65535

S141

Repeater Existence

0-*no repeater
1-1 or more repeaters exist

S142

Serial Channel Mode

0-*RS-232 interface
1-half-duplex RS-485
2-full-duplex RS-485

S143

Sleep Mode

0-*active (no sleep)
1-sleep mode 1, stays awake on local and air data
2-sleep mode 2, stays awake only on local data
3-sniff mode 1, stays awake on local and air data
4-sniff mode 2, stays awake only on local data
5-sniff mode 3, same as sniff mode 1 but will discard data if cannot find upstream unit

S144

Sleep Duration (seconds)

0-65535
*60

S145

Awake Timeout (seconds)

0-65535
*10

S149

LED Brightness (%)

0-100
*100

S150

Quick Sync Mode

0-*normal sync
1-quick sync mode, wait for acknowledgement
2-quick sync mode, wait for timeout

S151

Quick Sync Timeout (ms)

100-65534
*200

S153

Address Tag

0-*disable
1-enable

S158

FEC Mode

0 *No FEC
1 Hamming (7,4)
2 Hamming (15,11)
3 Hamming (31,24)
5 Binary BCH (47,36)
6 Golay (23,12,7)
7 Reed-Solomon (15,11)

S217

Protocol Type

0-*transparent
1-MODBUS RTU
2-DF1 protocol, address filtering

S237

Sniff Duration (hops)

1-255
*10

S244

Channel Request Mode

0-*channel request
1-TDMA mode
2-no channel request

S251

Master Hop Allocation Timeout (hops)

1-254
*10

Appendix E: Mounting Dimensions

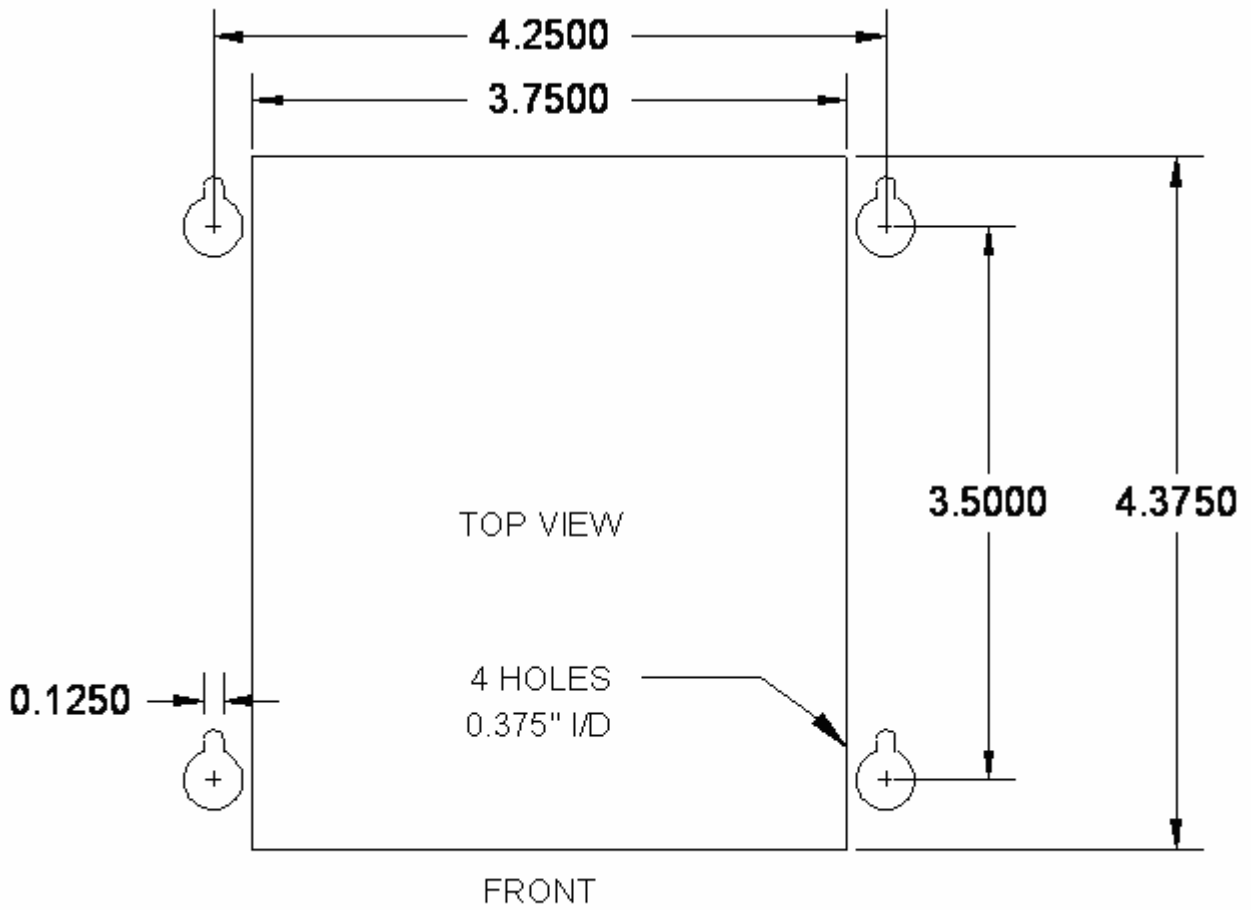

Appendix F: Serial Interface

Module (DCE)	Signal	Direction	Host Microprocessor (DTE)	Description
1	DCD	→	IN	<p>Arrows denote the direction that signals are asserted (e.g., DCD originates at the DCE and tells the DTE that a carrier is present).</p> <p>The MHX 2420 module uses 8 pins on the header connector for asynchronous serial I/O. The interface conforms to standard RS-232 signals without level shifting, so direct connection to a host microprocessor is possible.</p> <p>The signals in the asynchronous serial interface are described below:</p>
2	RX	→	IN	
3	← TX		OUT	
4	← DTR		OUT	
5	SG			
6	DSR	→	IN	
7	← RTS		OUT	
8	CTS	→	IN	

DCD *Data Carrier Detect* - Output from Module - When asserted (TTL low), DCD informs the DTE that a communications link has been established with another MHX 2420.

RX *Receive Data* - Output from Module - Signals transferred from the MHX 2420 are received by the DTE via RX.

TX *Transmit Data* - Input to Module - Signals are transmitted from the DTE via TX to the MHX 2420.

DTR *Data Terminal Ready* - Input to Module - Asserted (TTL low) by the DTE to inform the module that it is alive and ready for communications.

SG *Signal Ground* - Provides a ground reference for all signals transmitted by both DTE and DCE.

DSR *Data Set Ready* - Output from Module - Asserted (TTL low) by the DCE to inform the DTE that it is alive and ready for communications. DSR is the module's equivalent of the DTR signal.

RTS *Request to Send* - Input to Module - A "handshaking" signal which is asserted by the DTE (TTL low) when it is ready. When hardware handshaking is used, the RTS signal indicates to the DCE that the host can receive data.

CTS *Clear to Send* - Output from Module - A "handshaking" signal which is asserted by the DCE (TTL low) when it has enabled communications and transmission from the DTE can commence. When hardware handshaking is used, the CTS signal indicates to the host that the DCE can receive data.

Notes: It is typical to refer to RX and TX from the perspective of the DTE. This should be kept in mind when looking at signals relative to the module (DCE); the module transmits data on the RX line, and receives on TX.

"DCE" and "module" are often synonymous since a module is typically a DCE device.

"DTE" is, in most applications, a device such as a host microprocessor.

Appendix G: RS-485 Wiring

The Spectra 2420 can be connected into a 2-wire or 4-wire RS-485 network. Transmission line termination should be placed only at the extreme ends of the data line if the RS-485 network runs at high data rates and has a long wiring run.

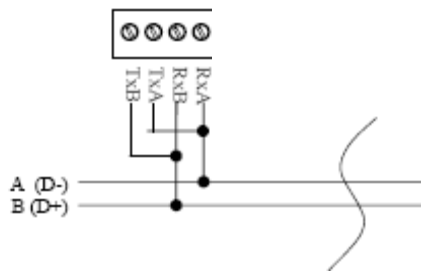

Figure G1: 2-wire RS-485 Configuration

2-wire RS-485

Figure G1 shows a typical two-wire configuration for an RS-485 connection to a Spectra 2420. Two wires are shared by transmitting and receiving in a 2-wire configuration, so it is very important for the modem to seize the line at the right time when it transmits. Note again that a transmission line termination is required if the system has high data rates and long wiring runs.

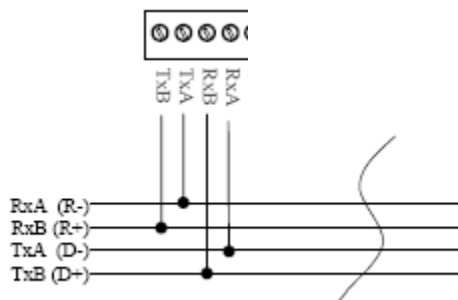

Figure G2: 4-wire RS-485 Configuration

4-wire RS-485

A Spectra 2420 can also be connected into a RS-485 network in a four-wire fashion as shown in Figure G2. In a four-wire network it is necessary that one node be a master node and all others be slaves. The network is connected so that the master node communicates to all slave nodes. All slave nodes communicate only with the master node. Since the slave nodes never listen to another slave response to the master, a slave node cannot reply incorrectly to another slave node.



17-2135-32 Avenue NE
Calgary, Alberta
Canada T2E 6Z3

Phone: (403) 248-0028
Fax: (403) 248-2762
www.microhardcorp.com